



Installation Manual

Mortuary Cooler Systems

1. Installation Preparation	2
2. Establishing Mortuary Perimeter	3
3. Vertical Panel Assembly	3
4. Installing Door Panel	4
5. Installing Ceiling Panels	4
6. Anchoring Mortuary Cooler	4
7. Caulking Mortuary Cooler	5
8. Installing Refrigeration Unit	5
9. Installing SaniTray Rack and Tray	5
10. Installing Telescoping Tray	6
Assembly of a 6 or 9 Body Cooler	7

1-800-24 BALLY

www.mortuarycoolers.com

Please read this instruction and any other installation material provided before starting the assembly of Bally Mortuary Cooler. A plan showing the proper locations of panels is enclosed.

1. Installation Preparation

- A. When the building is delivered, make sure you have the right equipment and manpower on hand to unload the truck. A forklift or high jack can be helpful if the shipment includes heavy steel or refrigeration equipment. The carrier typically imposes time constraints on unloading your box, and in all situations one person is not enough.
- B. As you are unloading look for any freight damage; all products left our factory in perfect condition. Once the Bill of Landing was signed by the carrier, safe delivery became their responsibility and the equipment became your property. Check the packing list and make sure that all component parts are accounted for. Before signing the Bill of Landing, inspect all items. If any damage is noted or the number of pieces received does not agree with the invoice, do not accept shipment without notation by the carrier's agent on the Freight Bill. If damage or shortage is discovered when unpacking leave material and request an inspection by the carrier. Keep all documents and information so you can file you claim properly with the carrier. The Bill of Landing, Freight Bill, and the original invoice, are need to file a claim, and must be filed within the first six months from the date of shipment.

Do not substitute hardware or other materials supplied. If there are questions or missing components, call the Bally Mortuary Sales Department at 1-800/24BALLY (1-800-242-2559)

- C. Use extreme caution when unpacking to prevent damage to panels and other equipment. Pay close attention to hardware affixed to the door and door-frame. Do not lift the door by its Hardware or the Light Base. Do not drop panels or slide over unfinished surfaces. Keep panels dry and out of direct sunlight. The protective plastic coating on the panels may be removed before or after the installation depending on the timing of construction schedules.
- D. Check the packing list and make sure that all components are included in the shipment.
- E. The most important requirement for o successful assembly is that the floor is level so that the panels will align correctly and be plumb. Have a plumb line and level available during the installation and check panel plumbness and levelness frequently.
- F. The vertical and door panels are pre-numbered and must be positioned as depicted in the Plan View.
- G. Familiarize yourself with the operation of the Speed-Loks. Study the figures and perform o few trial locks before actual assembly. Speed-Loks are accessed from the interior of Mortuary Cooler. Turn Speed-Lok wrench clockwise to engage the locking arm. See Figures 1, 2 and 3.

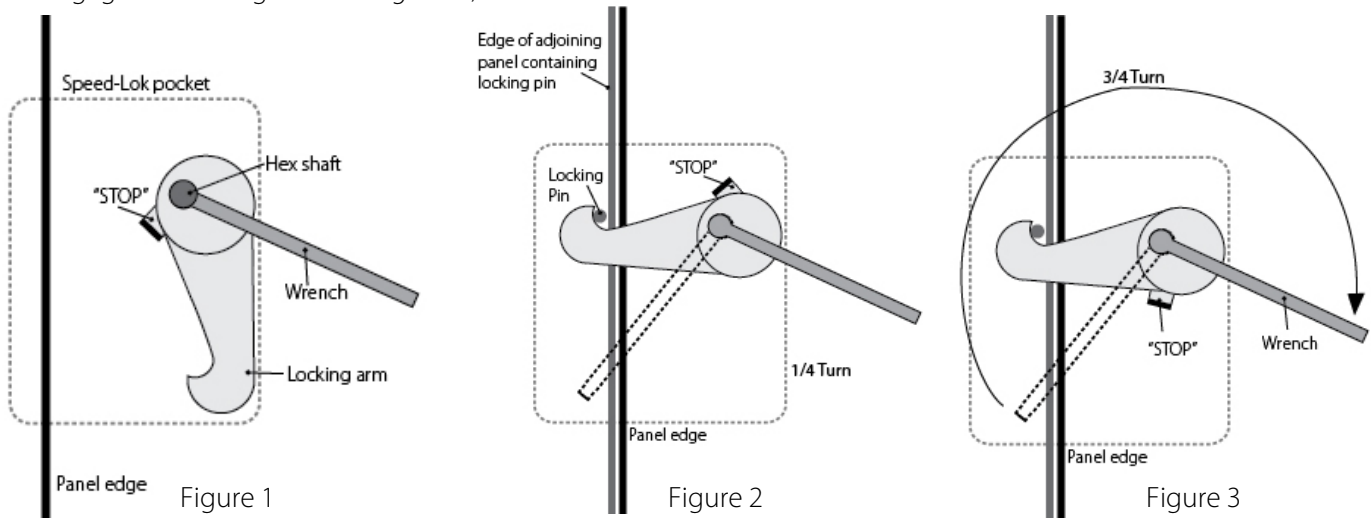

Establishing Mortuary Cooler Perimeter

- The following instructions cover the erection of Mortuary Coolers that do not include Bally floor panels and are shipped unassembled.
- Mark the outside perimeter of the Mortuary Cooler on the building floor. Check the marked area for squareness by measuring the distance across the corners as shown in *Figure 4*. Check floor for levelness. If floor is not level, the panels will need to be shimmed to maintain the height of the highest point of floor. Determine the highest point of floor using a 48" spirit level. If needed, establish a level string to help set vertical panels. See *Figure 5*.

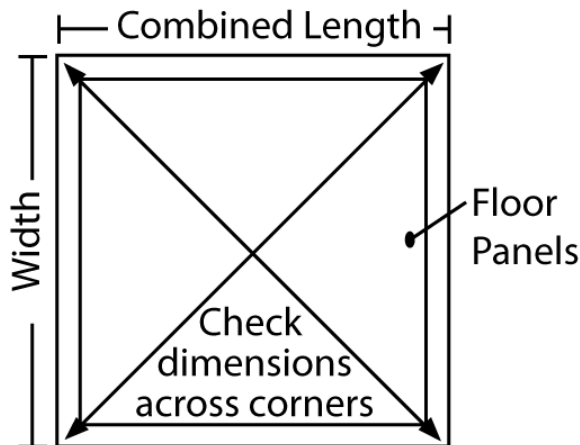

Figure 4:
Check Perimeter Outline

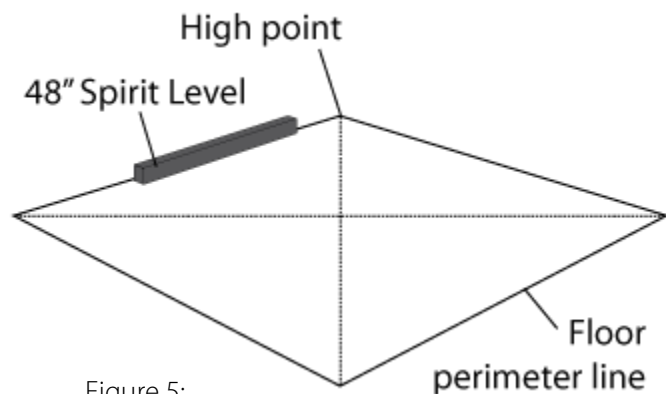

Figure 5:
Check Floor level

Vertical Panel Assembly

- Position the first corner panel (#1) so the outside of the panel is flush with the perimeter line. If necessary, shim corner panel to be level with the highest point of floor.
- Position the center back vertical panel (#2) to the corner panel and lock the adjoining side Speed-Loks. Shim the second panel if necessary for it to be plumb and level with the corner panel. Ensure that the tops of the panels are even. Insert Speed-Lok wrench into access hole and turn clockwise until the Speed-Lok locking arm stops. If Speed-Lok was fully open, the wrench should make one complete turn. See *Figure 6 and 7*.
- Position the next rear corner panel and lock to previously installed vertical panel. Check panels for plumbness and levelness.
- Proceed to position and lock the side vertical panels as numbered. Check each vertical panel for plumb and level when installed.

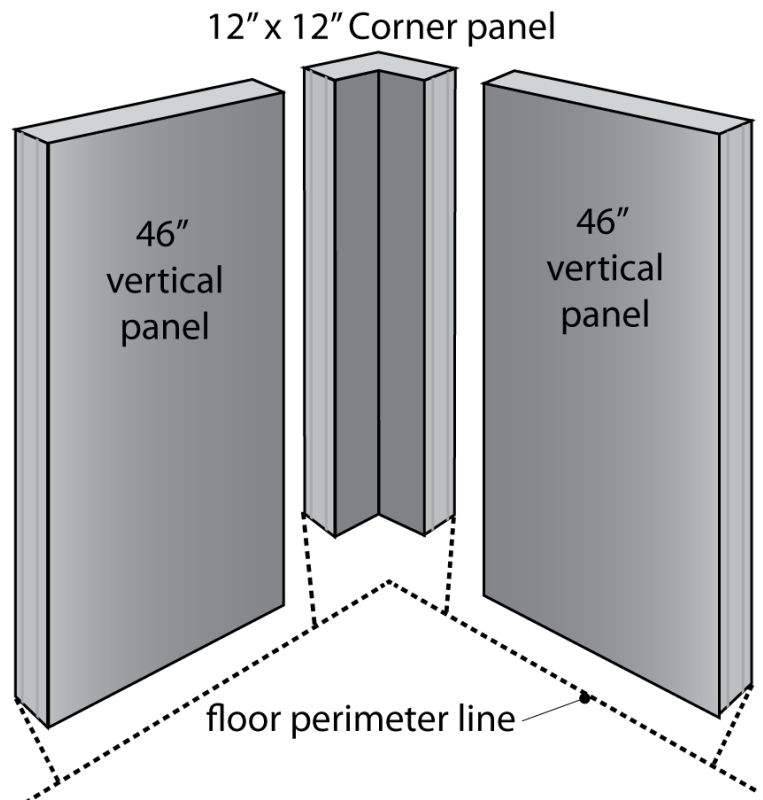
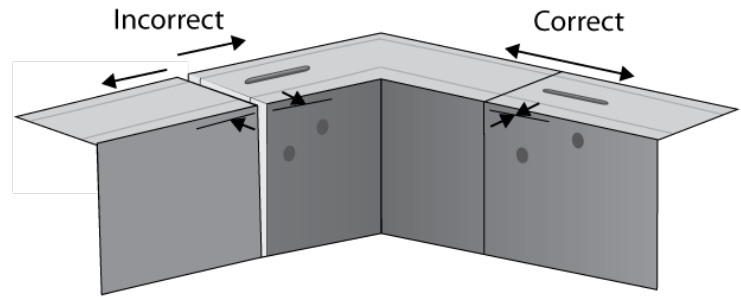

Figure 6:
Position Vertical Panels

Installing Door Panel

- A. Remove the steel-shipping strap mounted at the bottom of door panel opening. Position door panel and align with vertical panels previously installed.
- B. Door panel is considerably heavier than vertical panels and needs to be handled by at least (2) able-bodied personnel. Ensure that door panel is plumb and level and lock the adjoining Speed-Loks. Shim door panel if needed. If door panel is not installed plumb and level, the door will not operate properly.



Prior to engaging vertical to full locking position check metal to metal alignment at points indicated. This will assure you of a neat installation, and maintain all panels on a true horizontal plane.

Figure 7:
Lock Verticals Even at Top

Installing Ceiling Panels

- A. The Mortuary Cooler ceiling is made up of (2) ceiling panels that are locked together at the factory. Unlocking the ceiling panels will damage the refrigeration unit opening.
- B. Place ceiling panels on top of Mortuary as shown on the plan view. Align the edges with the vertical panels and lock top Speed-Loks.

Anchoring Mortuary Cooler

- A. Vertical panels are mounted to the building floor using continuous angle, concrete anchors and self-drilling metal (TEK) screws.
- B. Angles are shipped in stock lengths and must be cut before installation. Calculate angle length by measuring inside of wall panels and subtract 4 ". Angles will start 2" from each end wall. See Figure 8.
- C. Set angle along bottom of vertical panels with larger holes on floor and mark concrete anchor holes with a builders crayon or similar method.
- D. Drill 1/4" hole 2" deep in concrete at marked locations. Set angles back in place and install concrete anchors. Install self-drilling metal screws (TEK) through upright leg of angle through predrilled holes.

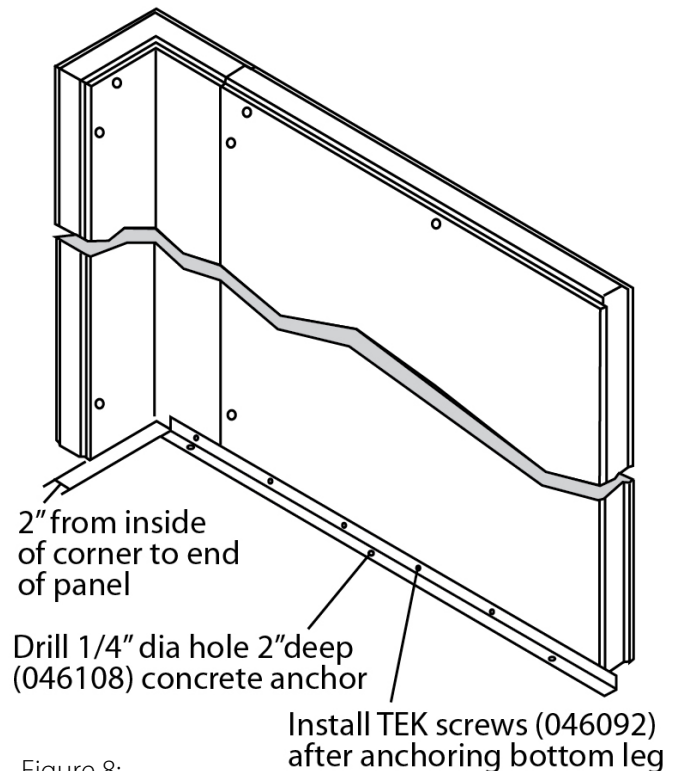

Figure 8:
Mortuary Cooler Anchoring

Caulking Mortuary Cooler

- A. Make final checks of Mortuary Cooler panels for a square and plumb installation. Add or remove shims as needed.
- B. Caulk bottom of the exterior and interior of wall panels using a silicone sealant that is mildew and waterproof.

Installing Refrigeration Unit

- A. Refrigeration unit is positioned as shown on plan view. Use the listed weights of refrigeration units to determine the method of lifting. The end of the refrigeration unit that is opposite of the bottom vent is the heavier end containing the compressor. Cardboard placed on top of Mortuary Cooler will help slide refrigeration unit into place and protect exterior finish.

Ensure that refrigeration unit is not stored or moved from horizontal.

Installing SaniTray Rack and Tray

- A. The SaniTray cross members and side rails on the 1-3 body cooler are identical.
- B. Position cross members within vertical channel slots with the ball bearing side facing up and the open side facing to the rear. Install clamp halves and hardware and tighten when cross member is level and at desired height. See Figure 9 and 10.
- C. The guide channels are marked left and right and top, middle (if there is a third tier) and bottom. These must be positioned as marked. It will be easier to adjust and secure guide channels if bottom guide channels are mounted first and then the next immediate levels.
- D. Position bottom level guide channels with the open ends facing inwards. Install mounting hardware loosely and slide body tray fully into Mortuary Cooler. Align body tray within guide channel adjustment to slide straight out of Mortuary Cooler. Tighten hardware for guide channels. Guide channels should fit loosely against body tray. Remove body tray out the way before installing next row of guide channels.

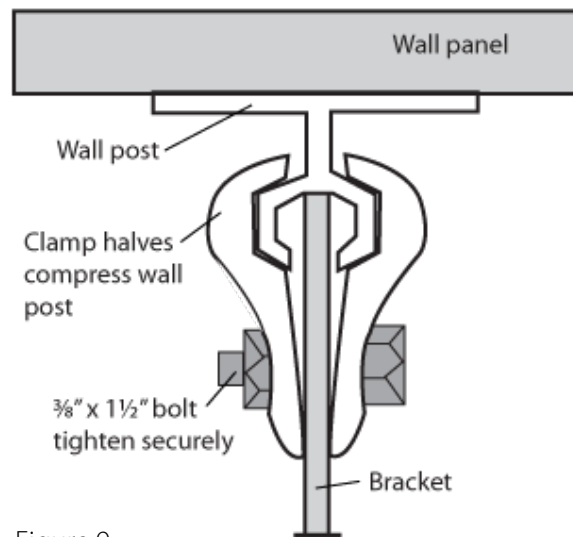

Figure 9:
Clamp Detail for Body Tray Racks

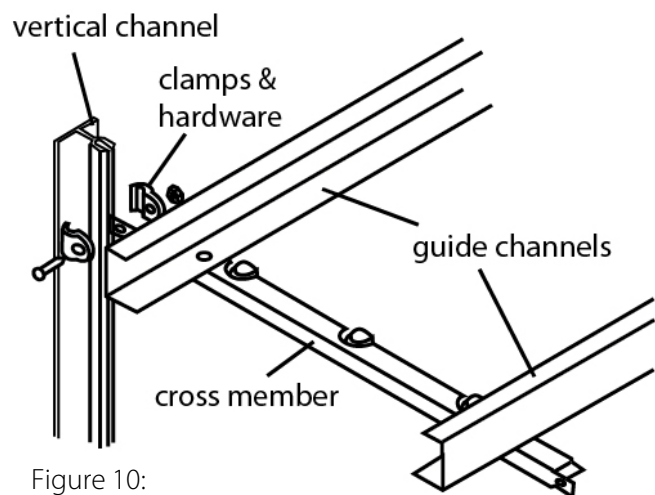

Figure 10:
Assembly of Body Tray Rack

Installing the Telescoping Body Tray Assembly

1. With the back and two sidewalls erected and fastened together, place the telescoping tray assembly into the partially constructed box. *See Figure 11.* Insure that the ends of each cross brace are inserted into the vertical struts. *See Figure 11a.*
2. Raise and suspend the assembly to the desired height with temporary supports. *See Figure 12.*
3. At this time, securely fasten the cross braces to the supports struts with the furnished clamps. *See Figure 13.*

Figure 11:
Telescoping tray inserted at a 45° angle.



Figure 11a:
Assembly tray inserted into the vertical struts.



Figure 12:
View of raised tray assembly on temporary supports.



Figure 13:
Cross braces attached to struts with clamps.
See Figure 9 on pg 5.



Proper order in which the clamps should be attached.