

PRODUCT DATA & SPECIFICATIONS

Bulletin B40-RPH-PDS-13
1064615

Indoor & Outdoor Air Cooled
Hermetic Condensing Units

1/2 to 5 HP

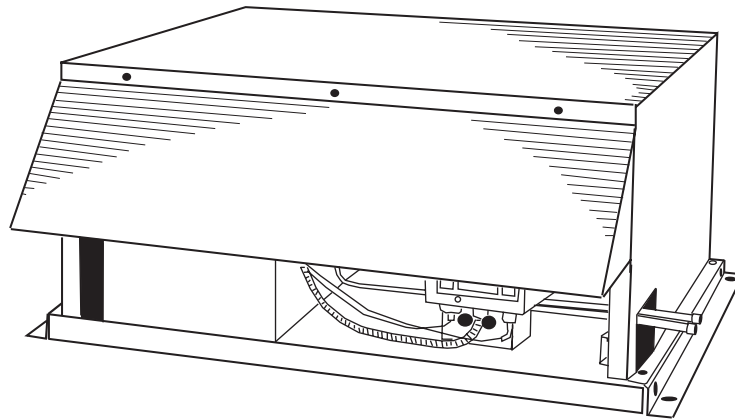

CONTENTS

	Page
Features.....	2
Nomenclature.....	2
 CAPACITY DATA 60Hz	
R22 - High/Medium Temp.....	3
R404/R507 - Medium Temp.....	4
R404A/R507 Extended - Medium Temp.....	5
R407A/R507 - Low Temp.....	6
 Electrical Specifications 60 Hz.....	 7, 8
 CAPACITY DATA 50Hz	
R22 - High/Medium Temp.....	10
R404/R507 - Medium Temp.....	11
R404A/R507 Extended - Medium Temp.....	12
R407A/R507 - Low Temp.....	13
 Electrical Specifications 50 Hz.....	 14, 15
 Dimensional Data.....	 16
Specifications 60Hz & 50 Hz.....	17, 18

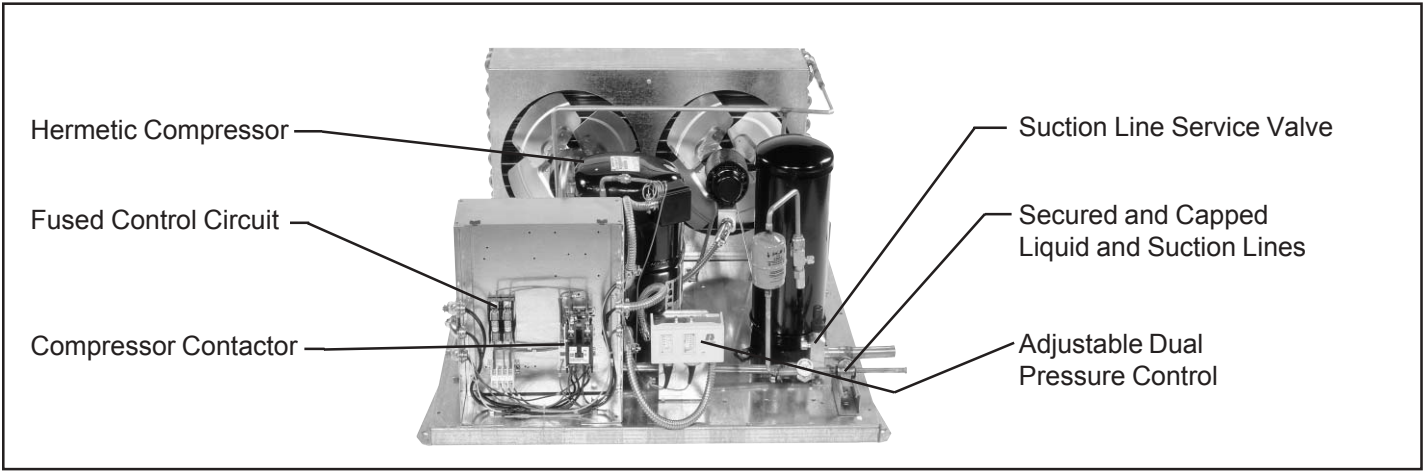

FEATURES

FEATURES AND OPTIONS

Indoor Unit

Standard Features Include:

- Weatherproof electrical control box with compressor contactor and fused control circuit
- Welded hermetic compressor
- Copper tubing secured with Hydra-Zorb / Cush-A-Clamp
- Receiver with fusible plug and liquid shut off valve
- Sealed liquid line filter drier and sight glass
- Adjustable dual high / low pressure control
- Suction service valve
- Time clock factory mounted and wired (Low Temp Units)

OPTIONAL FEATURES (FACTORY MOUNTED)

- Suction accumulator
- Sealed suction filter
- Heated and insulated receiver
- Liquid line solenoid valve with 230 volt coil (shipped loose)
- Ball valve (shipped loose)
- Compressor circuit breaker
- Compressor time delay relay
- Pump down toggle switch
- Defrost contactor with fuse block
- Evaporator fan contactor with fuse block
- Fixed or adjustable ambient fan cycling thermostat or pressure fan cycling control on 2 or more fan models
- Fused disconnect
- Phase / voltage monitor

OTHER OPTIONS AVAILABLE AT YOUR REQUEST - CONSULT FACTORY

Outdoor Unit

All Standard Features of Indoor Unit, Plus:

- Outdoor weather-resistant housing with removable hood
- Flooded head pressure control (non adjustable)
- Crankcase heater

NOMENCLATURE

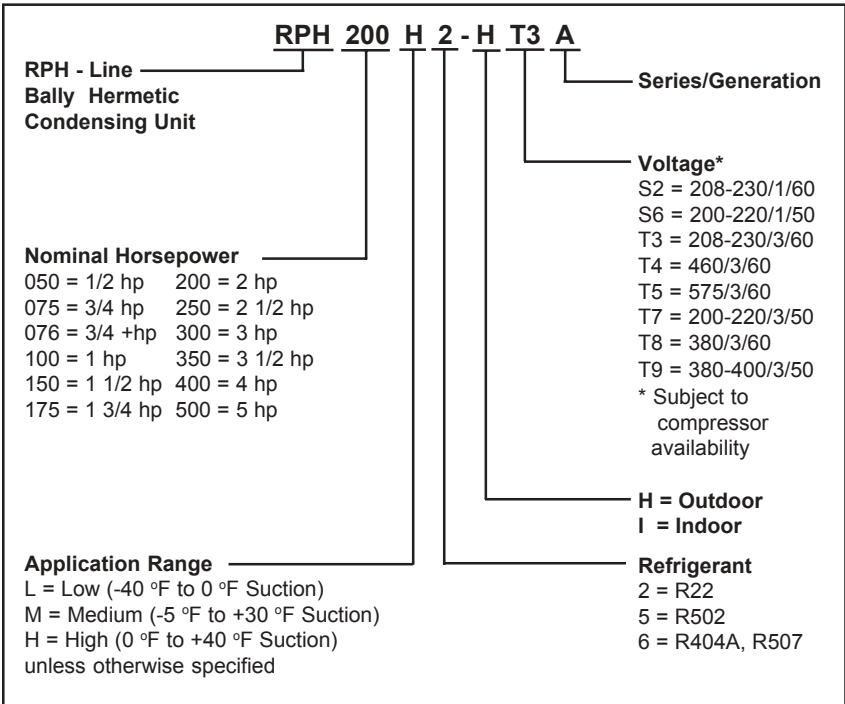

60Hz PERFORMANCE CAPACITY

Application Data Calculated at 65 °F. Return Gas, 0 °F. Liquid Subcooling

R22 - HIGH/MEDIUM TEMPERATURE - CAPACITY (BTU/HR)

Unit Shipped with mineral oil

COND. UNIT MODEL	SAT. SUCTION TEMP. ° F	80 ° F Amb.	90 ° F Amb.	95 ° F Amb.	100 ° F Amb.	105 ° F Amb.
RPH050H2 Compressor Model JRF4-0050	40	8642	7963	7612	7283	6978
	30	6968	6404	6150	5839	5584
	25	6197	5721	5438	5206	4958
	20	5507	5042	4818	4607	4382
	10*	4332	3963	3778	3594	3410
RPH075H2 Compressor Model RRG4-0100	40	11423	10414	9955	9497	9091
	30	9337	8527	8120	7710	7252
	25	8314	7556	7229	6810	6441
	20	7380	6694	6355	5994	5653
	10	5706	5124	4844	4564	4284
RPH100H2 Compressor Model REK3-0125	40	14777	13515	12934	12350	11832
	30	12061	11000	10484	9918	9451
	25	10755	9785	9299	8812	8325
	20	9551	8633	8173	7713	7253
	10*	7386	6554	6138	5721	5305
RPH150H2 Compressor Model CRA1-0150	40	19433	18113	17410	16705	16001
	30	15753	14598	14021	13443	12865
	25	13989	12951	12431	11961	11440
	20	12338	11408	10943	10479	10015
	10	9166	8446	8052	7695	7339
RPH200H2 Compressor Model CRD1-0200	40	24728	22926	22185	21359	20532
	30	20073	18653	17973	17293	16612
	25	17712	16497	15888	15280	14671
	20	15613	14527	13984	13441	12898
	10	11590	10753	10297	9882	9466
RPH300H2 Compressor Model CRJ3-0300	40	35760	33035	31715	30436	29050
	30	29205	27026	25856	25076	23834
	25	26236	24105	23243	22126	21141
	20	23080	21282	20409	19534	18660
	10	17377	16037	15365	14619	13946
RPH400H2 Compressor Model CRM3-0400	40	52318	48722	46918	45110	43154
	30	42304	39178	37496	35922	34484
	25	37661	34557	33223	31777	30320
	20	33081	30346	29028	27707	26386
	10*	24510	22403	21266	20215	19238
RPH500H2 Compressor Model CRN5-0500	40	59589	55433	53445	51452	49455
	30	48149	44688	43094	41353	39355
	25	42908	39717	38111	36378	34770
	20	37744	34818	33238	31768	30297
	10*	28057	25703	24480	23344	22082

* For +10 °F Sat. Suction Temps. Maximum return Gas Temp. +40 °F

60Hz PERFORMANCE CAPACITY

Application Data Calculated at 65 °F. Return Gas, 0 °F. Liquid Subcooling

R404A, R507 - MEDIUM TEMPERATURE - CAPACITY (BTU/HR)

Unit Shipped with polyolester oil

COND. UNIT MODEL	SAT. SUCTION TEMP. °F	80 °F Amb.	90 °F Amb.	95 °F Amb.	100 °F Amb.	105 °F Amb.
RPH050M6 Compressor Model RS43C1E	30	8000	7040	6560	6040	5580
	25	7250	6370	5890	5460	5030
	20	6510	5670	5270	4880	4490
	10	5020	4390	4080	3770	3460
	0	3630	3190	2980	2770	2560
RPH075M6 Compressor Model RS64C1E	30	9370	8355	7860	7350	6850
	25	8700	7750	7270	6810	6350
	20	7980	7130	6700	6270	5840
	10	6600	5870	5500	5150	4800
	0	5290	4680	4380	4080	3780
RP100M6 Compressor Model RS97C1E	30	16180	14460	13600	12750	11900
	25	14850	13270	12490	11720	10940
	20	13510	12080	11380	10670	9960
	10	10900	9730	9140	8560	7980
	0	8440	7480	7000	6530	6060
RPH150M6 Compressor Model CS10K6E	30	18320	16160	15090	14020	12980
	25	16730	14750	13750	12790	11820
	20	15130	13310	12420	11530	10630
	10	11960	10440	9690	8940	8190
	0	8910	7650	7020	6390	5770
RPH200M6 Compressor Model CS12K6E	30	20890	18600	17460	16340	15220
	25	19050	16940	15880	14850	13800
	20	17220	15270	14310	13340	12380
	10	13660	12010	11190	10380	9570
	0	10300	8940	8270	7590	6930
RPH250M6 Compressor Model CS14K6E	30	23230	20560	19300	18080	16830
	25	21340	18880	17750	16600	15450
	20	19340	17210	16160	15100	14060
	10	15670	13900	13020	12140	11260
	0	12210	10760	10030	9320	8615
RPH300M6 Compressor Model CS18K6E	30	31330	28010	26360	24520	22880
	25	28710	25635	23920	22400	20880
	20	26080	23080	21680	20280	18880
	10	20650	18330	17173	16020	14870
	0	15430	13640	12740	11850	10970
RPH350M6 Compressor Model CS20K6E	30	34380	30350	28430	26600	24700
	25	31390	27680	25970	24250	22520
	20	28230	25040	23460	21880	20295
	10	22460	19800	18470	17150	15830
	0	17130	14900	13800	12690	11600
RPH400M6 Compressor Model CS27K3E	30	44510	39710	37510	35310	33110
	25	40120	35940	33880	31800	29530
	20	36140	32260	30310	28160	26230
	10	28530	25070	23430	21800	20170
	0	21470	18870	17570	16280	15000
RPH500M6 Compressor Model CS33K3E	30	49630	44780	42110	39680	37290
	25	45620	40760	38470	36190	33920
	20	41650	37040	34880	32725	30580
	10	33630	29800	27700	25800	23910
	0	26290	22870	21250	19630	18040

60Hz PERFORMANCE CAPACITY

Application Data Calculated at 65 °F. Return Gas, 0 °F. Liquid Subcooling

R404A, R507 - EXTENDED MEDIUM TEMPERATURE - CAPACITY (BTU/HR)

For medium temperature range (0°F to 30°F) see page 4

Unit shipped with polyolester oil

COND. UNIT MODEL	SAT. SUCTION TEMP. °F	80°F	90°F	95°F	100°F	105°F
RPH050M6 Compressor Model RS43C1E	-5°F	3290	2940	2770	2600	2420
	-10°F	2820	2570	2450	2330	2200
	-15°F	2350	2150	2040	1940	1840
	-20°F	2010	1760	1640	1520	1400
	-25°F	1510	1360	1280	1200	1120
RPH075M6 Compressor Model RS64C1E	-5°F	4850	4310	4040	3760	3490
	-10°F	4280	3790	3540	3300	3050
	-15°F	3740	3290	3070	2840	2620
	-20°F	3220	2790	2580	2370	2150
	-25°F	2690	2300	2110	1910	1720
RPH100M6 Compressor Model RS97C1E	-5°F	7260	6430	6010	5590	5180
	-10°F	6310	5540	5160	4780	4400
	-15°F	5390	4690	4340	3980	3630
	-20°F	4560	3870	3520	3180	2830
	-25°F	3720	3050	2720	2390	2050
RPH150M6 Compressor Model CS10K6E	-5°F	7740	6650	6100	5560	5010
	-10°F	6520	5530	5040	4550	4050
	-15°F	5420	4520	4070	3630	3180
	-20°F	4500	3700	3300	2890	2490
	-25°F	3570	2850	2490	2130	1770
RPH200M6 Compressor Model CS12K6E	-5°F	9240	8010	7390	6770	6150
	-10°F	7870	6760	6210	5650	5100
	-15°F	6580	5600	5110	4620	4130
	-20°F	5490	4590	4150	3700	3250
	-25°F	4320	3560	3170	2790	2410
RPH250M6 Compressor Model CS14K6E	-5°F	10880	9580	8930	8280	7640
	-10°F	9360	8200	7630	7050	6470
	-15°F	7950	6930	6420	5910	5400
	-20°F	6780	5850	5390	4920	4460
	-25°F	5590	4760	4350	3930	3520
RPH300M6 Compressor Model CS18K6E	-5°F	13700	11960	11090	10220	9350
	-10°F	11660	10150	9400	8650	7890
	-15°F	9790	8510	7880	7240	6600
	-20°F	8300	7090	6490	5880	5270
	-25°F	6760	5750	5250	4750	4250
RPH350M6 Compressor Model CS20K6E	-5°F	15360	13280	12240	11200	10160
	-10°F	13370	11460	10510	9560	8610
	-15°F	11470	9700	8820	7940	7050
	-20°F	9640	7960	7110	6270	5430
	-25°F	7770	6200	5420	4630	3840
RPH400M6 Compressor Model CS27K3E	-5°F	19180	16700	15470	14230	12990
	-10°F	16630	14390	13280	12160	11050
	-15°F	14270	12260	11260	10250	9250
	-20°F	12240	10460	9580	8690	7800
	-25°F	10140	8580	7800	7020	6240
RPH500M6 Compressor Model CS33K3E	-5°F	22730	19760	18280	16800	15310
	-10°F	19890	17260	15940	14620	13300
	-15°F	17120	14840	13700	12560	11420
	-20°F	14400	12330	11290	10250	9220
	-25°F	11600	9890	9030	8170	7310

60Hz PERFORMANCE CAPACITY

Application Data Calculated at 65 °F. Return Gas, 0 °F. Liquid Subcooling

R404A, R507 - LOW TEMPERATURE - CAPACITY (BTU/HR)

Unit shipped with polyolester oil

COND. UNIT MODEL	SAT. SUCTION TEMP. °F	80°F	90°F	95°F	100°F	105°F
RPH050L6 Compressor Model AJ2419Z	-5°F	3570	3100	2870	2630	2410
	-10°F	3200	2750	2530	2310	2100
	-15°F	2830	2410	2210	2000	1800
	-20°F	2470	2080	1890	1700	1510
	-30°F	1790	1460	1300	1140	980
	-40°F	1150	900	770	640	460
RPH075L6 Compressor Model AJ2425Z	-5°F	5025	4340	4000	3670	3340
	-10°F	4350	3720	3410	3100	2790
	-15°F	3710	3130	2840	2560	2270
	-20°F	3120	2580	2320	2050	1800
	-30°F	2080	1630	1410	1200	980
	-40°F	1290	930	750	510	370
RPH099L6 Compressor Model AWA2440Z	-5°F	7950	6870	6330	5790	5250
	-10°F	6910	5940	5450	4970	4480
	-15°F	5900	5040	4610	4180	3750
	-20°F	4950	4200	3820	3450	3080
	-30°F	3240	2710	2440	2170	1910
	-40°F	1880	1570	1410	1250	1100
RPH151L6 Compressor Model AWA2460Z	-5°F	11770	10260	9510	8750	7990
	-10°F	10370	8990	8290	7600	6900
	-15°F	9000	7750	7120	6490	5870
	-20°F	7710	6590	6030	5470	4910
	-30°F	5340	4510	4090	3670	3250
	-40°F	3230	2660	2370	2090	1800
RPH201L6 Compressor Model AVA2490Z	-5°F	16100	14190	13230	12270	11320
	-10°F	14190	12480	11620	10770	9920
	-15°F	12390	10870	10120	9360	8600
	-20°F	10700	9370	8700	8030	7370
	-30°F	7670	6700	6220	5740	5260
	-40°F	5010	4290	3930	3560	3200
RPH290L6 Compressor Model AVA2512Z	-5°F	20420	17990	16780	15570	14360
	-10°F	17980	15820	14740	13660	12580
	-15°F	15690	13780	12820	11860	10900
	-20°F	13550	11870	11020	10180	9330
	-30°F	9710	8490	7880	7270	6660
	-40°F	6340	5430	4970	4510	4050

RPH - LINE 60 Hz ELECTRICAL SPECIFICATIONS

MODEL	POWER SUPPLY	COMPRESSOR		Condenser Fan(s)			TOTAL AMPS	M.C.A.	M.O.P
		RLA	LRA	QTY	Hp	FLA			
RPH050H2 - HS2	208-230/1/60	6.4	34	1	1/20	0.7	7.1	8.7	15
RPH075H2 - HS2	208-230/1/60	6.0	34	1	1/20	0.7	6.7	8.2	15
RPH100H2 - HS2	208-230/1/60	7.0	34	2	1/20	0.7	8.4	10.2	15
RPH100H2 - HT3	208-230/3/60	4.7	31	2	1/20	0.7	6.1	7.3	15
RPH150H2 - HS2	208-230/1/60	10.8	48	2	1/15	0.85	12.5	15.2	25
RPH150H2 - HT3	208-230/3/60	9.3	58	2	1/15	0.85	11.0	13.3	20
RPH150H2 - HT4	460/3/60	4.1	17	2	1/15	0.43	5.0	6.0	15
RPH200H2 - HS2	208-230/1/60	13.4	59	2	1/15	0.85	15.1	18.5	30
RPH200H2 - HT3	208-230/3/60	8.7	50	2	1/15	0.85	10.4	12.6	20
RPH200H2 - HT4	460/3/60	4.2	23	2	1/15	0.43	5.1	6.1	15
RPH300H2 - HS2	208-230/1/60	22.5	93	1	1/3	3.2	25.7	31.3	50
RPH300H2 - HT3	208-230/3/60	14.3	74	1	1/3	3.2	17.5	21.1	30
RPH300H2 - HT4	460/3/60	6.7	41	1	1/3	1.6	8.3	10.0	15
RPH400H2 - HS2	208-230/1/60	30.7	135	1	1/3	3.2	33.9	41.6	70
RPH400H2 - HT3	208-230/3/60	19.6	105	1	1/3	3.2	22.8	27.7	40
RPH400H2 - HT4	460/3/60	8.6	45	1	1/3	1.6	10.2	12.4	20
RPH500H2 - HS2	208-230/1/60	34.3	142	1	1/3	3.2	37.5	46.1	70
RPH500H2 - HT3	208-230/3/60	21.4	130	1	1/3	3.2	24.6	30.0	50
RPH500H2 - HT4	460/3/60	9.6	65	1	1/3	1.6	11.2	13.6	20

M.O.P. = Maximum Overcurrent Protection

M.C.A. = Minimum Circuit Ampacity

RPH - LINE 60 Hz ELECTRICAL SPECIFICATIONS

MODEL	POWER SUPPLY	COMPRESSOR		CONDENSER FANS			TOTAL AMPS	M.C.A.	M.O.P.
		RLA	LRA	QTY	HP @	FLA @			
RPH050M6 - HS2	208-230/1/60	5.7	24	1	1/20	0.7	6.4	7.8	15
RPH075M6 - HS2	208-230/1/60	9.2	45	1	1/20	0.7	9.9	12.2	20
RPH100M6 - HS2	208-230/1/60	11.0	51	2	1/20	0.7	12.4	15.2	20
RPH100M6 - HT3	208-230/3/60	7.0	35	2	1/20	0.7	8.4	10.2	15
RPH150M6 - HS2	208-230/1/60	10.9	56	2	1/15	0.85	12.6	15.3	20
RPH150M6 - HT3	208-230/3/60	7.5	51	2	1/15	0.85	9.2	11.1	15
RPH150M6 - HT4	460/3/60	3.6	25	2	1/15	0.43	4.5	5.4	15
RPH200M6 - HS2	208-230/1/60	10.9	56	2	1/15	0.85	12.6	15.3	20
RPH200M6 - HT3	208-230/3/60	7.5	51	2	1/15	0.85	9.2	11.1	15
RPH250M6 - HS2	208-230/1/60	12.4	61	2	1/15	0.85	14.1	17.2	25
RPH250M6 - HT3	208-230/3/60	9.1	55	2	1/15	0.85	10.8	13.1	20
RPH250M6 - HT4	460/3/60	4.7	28	2	1/15	0.43	5.6	6.7	15
RPH300M6 - HS2	208-230/1/60	16.0	82	1	1/3	3.2	19.2	23.2	30
RPH300M6 - HT3	208-230/3/60	10.4	66	1	1/3	3.2	13.6	16.2	25
RPH300M6 - HT4	460/3/60	4.3	33	1	1/3	1.6	5.9	7.0	15
RPH350M6 - HS2	208-230/1/60	18.6	96	1	1/3	3.2	21.8	26.5	40
RPH350M6 - HT3	208-230/3/60	11.4	75	1	1/3	3.2	14.6	17.5	25
RPH350M6 - HT4	460/3/60	5.1	40	1	1/3	1.6	6.7	8.0	15
RPH400M6 - HS2	208-230/1/60	23.9	95	1	1/3	3.2	27.1	33.1	50
RPH400M6 - HT3	208-230/3/60	15.6	82	1	1/3	3.2	18.5	22.3	30
RPH400M6 - HT4	460/3/60	8.5	41	1	1/3	1.6	10.1	12.2	20
RPH500M6 - HS2	208-230/1/60	30.7	125	1	1/3	3.2	33.9	41.6	70
RPH500M6 - HT3	208-230/3/60	20.7	90	1	1/3	3.2	23.9	29.1	40
RPH500M6 - HT4	460/3/60	9.9	45	1	1/3	1.6	11.5	14.0	20
RPH050L6 - HS2	208-230/1/60	3.0	34	1	1/20	0.7	3.7	4.5	15
RPH075L6 - HS2	208-230/1/60	3.2	39	1	1/20	0.7	3.9	4.7	15
RPH099L6 - HS2	208-230/1/60	8.7	73	2	1/15	0.85	10.4	12.6	20
RPH099L6 - HT3	208-230/3/60	4.9	40.5	2	1/15	0.85	6.6	7.8	15
RPH151L6 - HS2	208-230/1/60	12.6	86	2	1/15	0.85	14.3	17.5	25
RPH151L6 - HT3	208-230/3/60	8.3	63.4	2	1/15	0.85	10.0	12.1	20
RPH201L6 - HS2	208-230/1/60	16.2	106.6	2	1/15	0.85	17.9	22.0	30
RPH201L6 - HT3	208-230/3/60	9.9	65.1	2	1/15	0.85	11.6	14.1	20
RPH201L6 - HT4	460/3/60	5.3	38.3	2	1/15	0.43	6.2	7.5	15
RPH290L6 - HS2	208-230/1/60	20.8	120.3	1	1/3	3.2	24.0	29.2	40
RPH290L6 - HT3	208-230/3/60	11.0	65.1	1	1/3	3.2	14.2	17.0	25
RPH290L6 - HT4	460/3/60	6.2	38.3	1	1/3	1.6	7.8	9.4	15

M.O.P. = Maximum Overcurrent Protection
M.C.A. = Minimum Circuit Ampacity

SPECIAL NOTE

**THE FOLLOWING SECTION
PAGES 10 TO 15
CONTAIN 50Hz DATA**

50Hz PERFORMANCE CAPACITY

Application Data Calculated at 65 °F. Return Gas, 0 °F. Liquid Subcooling

R22 - HIGH/MEDIUM TEMPERATURE - CAPACITY (BTU/HR)

Unit Shipped with mineral oil

COND. UNIT MODEL	SAT. SUCTION TEMP. °F	80 °F Amb.	90 °F Amb.	95 °F Amb.	100 °F Amb.	105 °F Amb.
RPH050H2 Compressor Model JRF4-0050	40	7346	6769	6471	6191	5932
	30	5923	5444	5229	4964	4747
	25	5268	4863	4623	4426	4215
	20	4681	4286	4096	3916	3725
	10*	3683	3369	3212	3055	2899
RPH075H2 Compressor Model RRG4-0100	40	9710	8852	8462	8073	7727
	30	7937	7248	6902	6554	6165
	25	7067	6423	6145	5789	5475
	20	6273	5690	5402	5095	4806
	10	4851	4356	4118	3880	3642
RPH100H2 Compressor Model REK3-0125	40	12561	11488	10994	10498	10058
	30	10252	9350	8912	8431	8034
	25	9142	8318	7905	7491	7077
	20	8119	7339	6948	6557	6166
	10*	6279	5571	5218	4863	4510
RPH150H2 Compressor Model CRA1-0150	40	16519	15397	14799	14200	13601
	30	13391	12409	11918	11427	10935
	25	11891	11009	10567	10167	9724
	20	10488	9697	9302	8908	8513
	10	7792	7180	6845	6541	6239
RPH200H2 Compressor Model CRD1-0200	40	21019	19488	18858	18156	17453
	30	17063	15856	15278	14700	14121
	25	15056	14023	13505	12988	12471
	20	13272	12348	11887	11425	10964
	10	9852	9141	8753	8400	8047
RPH300H2 Compressor Model CRJ3-0300	40	30396	28080	26958	25871	24693
	30	24825	22973	21978	21315	20259
	25	22301	20490	19757	18808	17970
	20	19618	18090	17348	16604	15861
	10	14771	13632	13061	12427	11855
RPH400H2 Compressor Model CRM3-0400	40	44471	41414	39881	38344	36681
	30	35959	33302	31872	30534	29312
	25	32012	29374	28240	27011	25772
	20	28119	25795	24674	23551	22429
	10*	20834	19043	18077	17183	16353
RPH500H2 Compressor Model CRN5-0500	40	50651	47119	45429	43735	42037
	30	40927	37985	36630	35151	33452
	25	36472	33760	32395	30922	29555
	20	32083	29596	28253	27003	25753
	10*	23849	21848	20808	19843	18770

* For +10 °F Sat. Suction Temps. Maximum return Gas temp. +40 °F.

50Hz PERFORMANCE CAPACITY

Application Data Calculated at 65 °F. Return Gas, 0 °F. Liquid Subcooling

R404A, R507 - MEDIUM TEMPERATURE - CAPACITY (BTU/HR)

Unit Shipped with polyolester oil

COND. UNIT MODEL	SAT. SUCTION TEMP. °F	80 °F Amb.	90 °F Amb.	95 °F Amb.	100 °F Amb.	105 °F Amb.
RPH050M6 Compressor Model RS43C1E	30	6800	5984	5576	5134	4743
	25	6163	5415	5007	4641	4276
	20	5534	4820	4480	4148	3817
	10	4267	3732	3468	3205	2941
	0	3086	2712	2533	2355	2176
RPH075M6 Compressor Model RS64C1E	30	7965	7102	6681	6248	5823
	25	7395	6588	6180	5789	5398
	20	6783	6061	5695	5330	4964
	10	5610	4990	4675	4378	4080
	0	4497	3978	3638	3468	3213
RP100M6 Compressor Model RS97C1E	30	13753	12291	11560	10838	10115
	25	12623	11280	10617	9962	9299
	20	11484	10268	9673	9070	8466
	10	9265	8271	7769	7276	6783
	0	7174	6358	5950	5551	5151
RPH150M6 Compressor Model CS10K6E	30	15572	13736	12827	11917	11033
	25	14221	12538	11688	10872	10047
	20	12861	11314	10557	9801	9036
	10	10166	8874	8237	7599	6962
	0	7574	6503	5967	5432	4905
RPH200M6 Compressor Model CS12K6E	30	17757	15810	14841	13889	12937
	25	16193	14399	13498	12623	11730
	20	14637	12980	12164	11339	10523
	10	11611	10209	9512	8823	8135
	0	8755	7599	7030	6452	5891
RPH250M6 Compressor Model CS14K6E	30	19746	17476	16405	15368	14306
	25	18139	16048	15088	14110	13133
	20	16439	14629	13736	12835	11951
	10	13320	11815	11067	10319	9571
	0	10379	9146	8526	7922	7323
RPH300M6 Compressor Model CS18K6E	30	26631	23809	22406	20842	19448
	25	24404	21790	20332	19040	17748
	20	22168	19618	18428	17238	16048
	10	17553	15581	14598	13617	12640
	0	13116	11594	10829	10073	9325
RPH350M6 Compressor Model CS20K6E	30	29223	25798	24166	22610	20995
	25	26682	23528	22075	20613	19142
	20	23996	21284	19941	18598	17251
	10	19091	16830	15701	14578	13456
	0	14561	12665	11730	10787	9860
RPH400M6 Compressor Model CS27K3E	30	37834	33754	31884	30014	28144
	25	34102	30549	28798	27030	25101
	20	30719	27421	25764	23936	22296
	10	24251	21310	19916	18530	17145
	0	18250	16040	14935	13838	12750
RPH500M6 Compressor Model CS33K3E	30	42186	38063	35794	33728	31697
	25	38777	34646	32700	30762	28832
	20	35403	31484	29648	27225	25993
	10	28586	25330	23545	21930	20324
	0	22347	19440	18063	16686	15334

50Hz PERFORMANCE CAPACITY

Application Data Calculated at 65 °F. Return Gas, 0 °F. Liquid Subcooling

R404A, R507 - EXTENDED MEDIUM TEMPERATURE - CAPACITY (BTU/HR)

For medium temperature range (0°F to 30°F) see page 11
Unit Shipped with polyolester oil

COND. UNIT MODEL	SAT. SUCTION TEMP. °F	80°F	90°F	95°F	100°F	105°F
RPH050M6 Compressor Model RS43C1E	-5°F	2797	2499	2355	2210	2057
	-10°F	2397	2185	2083	1981	1870
	-15°F	1998	1828	1734	1649	1564
	-20°F	1709	1496	1394	1292	1190
	-25°F	1284	1156	1088	1020	952
RPH075M6 Compressor Model RS64C1E	-5°F	4123	3664	3434	3196	2967
	-10°F	3638	3222	3009	2805	2593
	-15°F	3179	2797	2610	2414	2227
	-20°F	2737	2372	2193	2015	1828
	-25°F	2287	1955	1794	1624	1462
RPH100M6 Compressor Model RS97C1E	-5°F	6171	5466	5109	4752	4403
	-10°F	5364	4709	4386	4063	3740
	-15°F	4582	3987	3689	3383	3086
	-20°F	3876	3290	2992	2703	2406
	-25°F	3162	2593	2312	2032	1743
RPH150M6 Compressor Model CS10K6E	-5°F	6579	5653	5185	4726	4259
	-10°F	5542	4701	4284	3868	3443
	-15°F	4607	3842	3460	3086	2703
	-20°F	3825	3145	2805	2457	2117
	-25°F	3035	2423	2117	1811	1505
RPH200M6 Compressor Model CS12K6E	-5°F	7854	6809	6282	5755	5228
	-10°F	6690	5746	5279	4803	4335
	-15°F	5593	4760	4344	3927	3511
	-20°F	4667	3902	3528	3145	2763
	-25°F	3672	3026	2695	2372	2049
RPH250M6 Compressor Model CS14K6E	-5°F	9248	8143	7591	7038	6494
	-10°F	7956	6970	6486	5993	5500
	-15°F	6758	5891	5457	5024	4590
	-20°F	5673	4973	4582	4182	3791
	-25°F	4752	4046	3698	3341	2992
RPH300M6 Compressor Model CS18K6E	-5°F	11645	10166	9427	8687	7948
	-10°F	9911	8628	7990	7353	6707
	-15°F	8322	7234	6698	6154	5610
	-20°F	7055	6027	5517	4998	4480
	-25°F	5746	4888	4463	4038	3613
RPH350M6 Compressor Model CS20K6E	-5°F	13056	11288	10404	9520	8636
	-10°F	11365	9741	8934	8126	7319
	-15°F	9750	8245	7497	6749	5993
	-20°F	8194	6766	6044	5330	4616
	-25°F	6605	5270	4607	3936	3264
RPH400M6 Compressor Model CS27K3E	-5°F	16303	14195	13150	12096	11042
	-10°F	14136	12232	11288	10336	9393
	-15°F	12130	10421	9571	8713	7863
	-20°F	10404	8891	8143	7387	6630
	-25°F	8619	7293	6630	5967	5304
RPH500M6 Compressor Model CS33K3E	-5°F	19321	16796	15538	14280	13014
	-10°F	16907	14671	13549	12427	11305
	-15°F	14552	12614	11645	10676	9707
	-20°F	12240	10481	9597	8713	7837
	-25°F	9860	8407	7676	6945	6214

50Hz PERFORMANCE CAPACITY

Application Data Calculated at 65 °F. Return Gas, 0 °F. Liquid Subcooling

R404A, R507 - LOW TEMPERATURE - CAPACITY (BTU/HR)

Unit Shipped with polyolester oil

COND. UNIT MODEL	SAT. SUCTION TEMP. °F	80°F	90°F	95°F	100°F	105°F
RPH050L6 Compressor Model AJ2419Z	-5°F	3035	2635	2440	2236	2049
	-10°F	2720	2338	2151	1964	1785
	-15°F	2406	2049	1879	1700	1530
	-20°F	2100	1768	1607	1445	1284
	-30°F	1522	1241	1105	969	833
	-40°F	978	765	655	544	391
RPH075L6 Compressor Model AJ2425Z	-5°F	4271	3689	3400	3120	2839
	-10°F	3698	3162	2899	2635	2372
	-15°F	3154	2661	2414	2176	1930
	-20°F	2652	2193	1972	1743	1530
	-30°F	1768	1386	1199	1020	833
	-40°F	1097	791	638	434	315
RPH099L6 Compressor Model AWA2440Z	-5°F	6758	5840	5381	4922	4463
	-10°F	5874	5049	4633	4225	3808
	-15°F	5015	4284	3919	3553	3188
	-20°F	4208	3570	3247	2933	2618
	-30°F	2754	2304	2074	1845	1624
	-40°F	1598	1335	1199	1063	935
RPH151L6 Compressor Model AWA2460Z	-5°F	10005	8721	8084	7438	6792
	-10°F	8815	7642	7047	6460	5865
	-15°F	7650	6588	6052	5517	4990
	-20°F	6554	5602	5126	4650	4174
	-30°F	4539	3834	3477	3120	2763
	-40°F	2746	2261	2015	1777	1530
RPH201L6 Compressor Model AVA2490Z	-5°F	13685	12062	11246	10430	9622
	-10°F	12062	10608	9877	9155	8432
	-15°F	10532	9240	8602	7956	7310
	-20°F	9095	7965	7395	6826	6265
	-30°F	6520	5695	5287	4879	4471
	-40°F	4259	3647	3341	3026	2720
RPH290L6 Compressor Model AVA2512Z	-5°F	17357	15292	14263	13235	12206
	-10°F	15283	13447	12529	1161	10693
	-15°F	13337	11713	10897	10081	9265
	-20°F	11518	10090	9367	8653	7931
	-30°F	8254	7217	6698	6180	5661
	-40°F	5389	4616	4225	3834	3443

M.O.P. = Maximum Overcurrent Protection

M.C.A. = Minimum Circuit Ampacity

RPH - LINE 50 Hz ELECTRICAL SPECIFICATIONS

MODEL	POWER SUPPLY	COMPRESSOR		Condenser Fan(s)			TOTAL AMPS	M.C.-A.	M.O.-P
		RLA	LRA	QTY	Hp	FLA			
RPH050H2 - HS6	200-200/1/50	6.4	34	1	1/20	0.7	7.1	8.7	15
RPH075H2 - HS6	200-200/1/50	6.0	34	1	1/20	0.7	6.7	8.2	15
RPH100H2 - HS6	200-200/1/50	7.0	34	2	1/20	0.7	8.4	10.2	15
RPH100H2 - HT7	200-200/3/50	4.7	31	2	1/20	0.7	6.1	7.3	15
RPH150H2 - HS6	200-200/1/50	10.8	48	2	1/15	0.85	12.5	15.2	25
RPH150H2 - HT7	200-200/3/50	9.3	58	2	1/15	0.85	11.0	13.3	20
RPH150H2 - HT9	380-400/3/50	4.1	17	2	1/15	0.43	5.0	6.0	15
RPH200H2 - HS6	200-200/1/50	13.4	59	2	1/15	0.85	15.1	18.5	30
RPH200H2 - HT7	200-200/3/50	8.7	50	2	1/15	0.85	10.4	12.6	20
RPH200H2 - HT9	380-400/3/50	4.2	23	2	1/15	0.43	5.1	6.1	15
RPH300H2 - HS6	200-200/1/50	22.5	93	1	1/3	3.2	25.7	31.3	50
RPH300H2 - HT7	200-200/3/50	14.3	74	1	1/3	3.2	17.5	21.1	30
RPH300H2 - HT9	380-400/3/50	6.7	41	1	1/3	1.6	8.3	10.0	15
RPH400H2 - HS6	200-200/1/50	30.7	135	1	1/3	3.2	33.9	41.6	70
RPH400H2 - HT7	200-200/3/50	19.6	105	1	1/3	3.2	22.8	27.7	40
RPH400H2 - HT4	380-400/3/50	8.6	45	1	1/3	1.6	10.2	12.4	20
RPH500H2 - HS6	200-200/1/50	34.3	142	1	1/3	3.2	37.5	46.1	70
RPH500H2 - HT7	200-200/3/50	21.4	130	1	1/3	3.2	24.6	30.0	50
RPH500H2 - HT9	380-400/3/50	9.6	65	1	1/3	1.6	11.2	13.6	20

M.O.P. = Maximum Overcurrent Protection

M.C.A. = Minimum Circuit Ampacity

RPH - LINE 50 Hz ELECTRICAL SPECIFICATIONS

MODEL	POWER SUPPLY	COMPRESSOR		CONDENSER FANS			TOTAL AMPS	M.C.A.	M.O.P.
		RLA	LRA	QTY	HP @	FLA @			
RPH050M6 - HS6	200-220/1/50	5.7	24	1	1/20	0.7	6.4	7.8	15
RPH075M6 - HS6	200-220/1/50	9.2	45	1	1/20	0.7	9.9	12.2	20
RPH100M6 - HS6	200-220/1/50	11.0	51	2	1/20	0.7	12.4	15.2	20
RPH100M6 - HT7	200-220/3/50	7.0	35	2	1/20	0.7	8.4	10.2	15
RPH150M6 - HS6	200-220/1/50	10.9	56	2	1/15	0.85	12.6	15.3	20
RPH150M6 - HT7	200-220/3/50	7.5	51	2	1/15	0.85	9.2	11.1	15
RPH150M6 - HT9	380-400/3/50	3.6	25	2	1/15	0.43	4.5	5.4	15
RPH200M6 - HS6	200-220/1/50	10.9	56	2	1/15	0.85	12.6	15.3	20
RPH200M6 - HT7	200-220/3/50	7.5	51	2	1/15	0.85	9.2	11.1	15
RPH250M6 - HS6	200-220/1/50	12.4	61	2	1/15	0.85	14.1	17.2	25
RPH250M6 - HT7	200-220/3/50	9.1	55	2	1/15	0.85	10.8	13.1	20
RPH250M6 - HT9	380-400/3/50	4.7	28	2	1/15	0.43	5.6	6.7	15
RPH300M6 - HS6	200-220/1/50	16.0	82	1	1/3	3.2	19.2	23.2	30
RPH300M6 - HT7	200-220/3/50	10.4	66	1	1/3	3.2	13.6	16.2	25
RPH300M6 - HT9	380-400/3/50	4.3	33	1	1/3	1.6	5.9	7.0	15
RPH350M6 - HS6	200-220/1/50	18.6	96	1	1/3	3.2	21.8	26.5	40
RPH350M6 - HT7	200-220/3/50	11.4	75	1	1/3	3.2	14.6	17.5	25
RPH350M6 - HT9	380-400/3/50	5.1	40	1	1/3	1.6	6.7	8.0	15
RPH400M6 - HS6	200-220/1/50	23.9	95	1	1/3	3.2	27.1	33.1	50
RPH400M6 - HT7	200-220/3/50	15.6	82	1	1/3	3.2	18.5	22.3	30
RPH400M6 - HT9	380-400/3/50	8.5	41	1	1/3	1.6	10.1	12.2	20
RPH500M6 - HS6	200-220/1/50	30.7	125	1	1/3	3.2	33.9	41.6	70
RPH500M6 - HT7	200-220/3/50	20.7	90	1	1/3	3.2	23.9	29.1	40
RPH500M6 - HT9	380-400/3/50	9.9	45	1	1/3	1.6	11.5	14.0	20
RPH050L6 - HS6	200-220/1/50	3.0	34	1	1/20	0.7	3.7	4.5	15
RPH075L6 - HS6	200-220/1/50	3.2	39	1	1/20	0.7	3.9	4.7	15
RPH099L6 - HS6	200-220/1/50	8.7	73	2	1/15	0.85	10.4	12.6	20
RPH099L6 - HT7	200-220/3/50	4.9	40.5	2	1/15	0.85	6.6	7.8	15
RPH151L6 - HS6	200-220/1/50	12.6	86	2	1/15	0.85	14.3	17.5	25
RPH151L6 - HT7	200-220/3/50	8.3	63.4	2	1/15	0.85	10.0	12.1	20
RPH201L6 - HS6	200-220/1/50	16.2	106.6	2	1/15	0.85	17.9	22.0	30
RPH201L6 - HT7	200-220/3/50	9.9	65.1	2	1/15	0.85	11.6	14.1	20
RPH201L6 - HT9	380-400/3/50	5.3	38.3	2	1/15	0.43	6.2	7.5	15
RPH290L6 - HS6	200-220/1/50	20.8	120.3	1	1/3	3.2	24.0	29.2	40
RPH290L6 - HT7	200-220/3/50	11.0	65.1	1	1/3	3.2	14.2	17.0	25
RPH290L6 - HT9	380-400/3/50	6.2	38.3	1	1/3	1.6	7.8	9.4	15

M.O.P. = Maximum Overcurrent Protection

M.C.A. = Minimum Circuit Ampacity

RPH - LINE DIMENSIONAL DATA

1/2 AND 3/4 HP

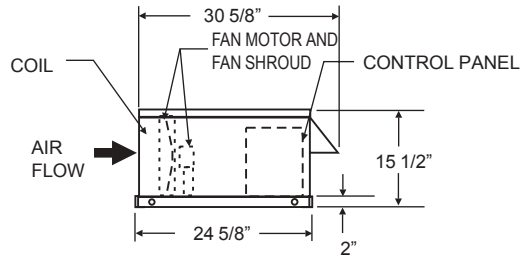
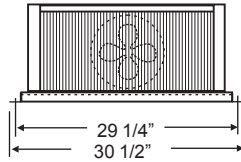
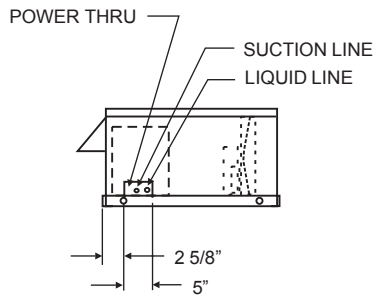

1 HP

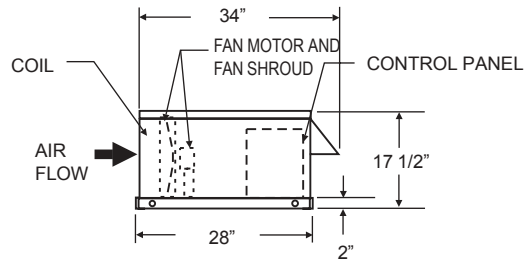
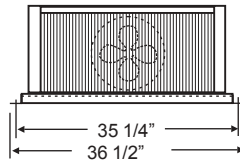
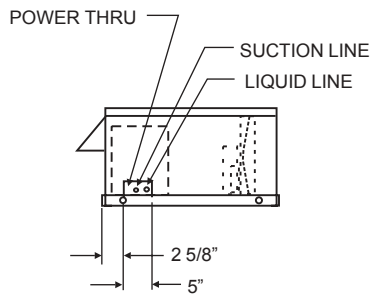

1 1/2 AND 2 1/2 HP

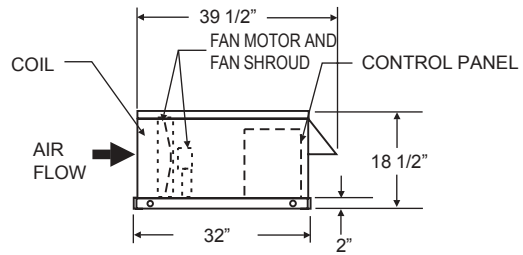
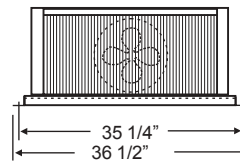
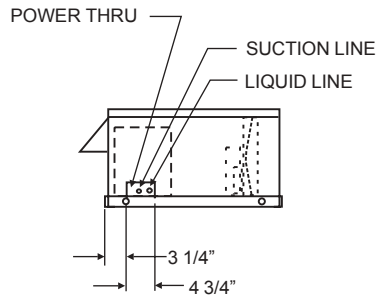

3, 4 AND 5 HP

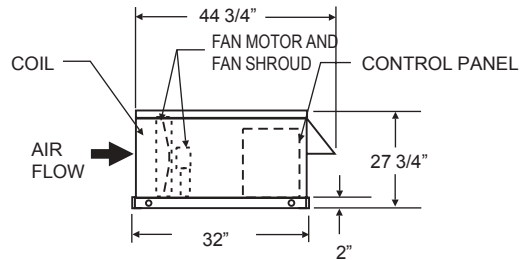
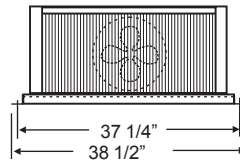
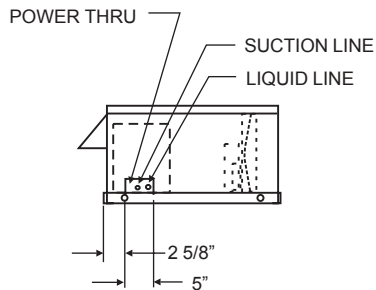

RPH - LINE SPECIFICATIONS

MODEL	COMPRESSOR	CONNECTIONS		RECEIVER CAPACITY @ 90% FULL (LBS)	SHIPPING WT. (LBS)
		LIQUID (OD)	SUCTION (OD)		
RPH050H2 - HS2	JRF4 - 0050	3/8	1/2	6	180
RPH075H2 - HS2	RRG4 - 0100	3/8	5/8	6	200
RPH100H2 - HS2, HT3	REK3 - 0125	3/8	5/8	9	250
RPH150H2 - HS2, HT3, HT4	CRA1 - 0150	3/8	7/8	15	290
RPH200H2 - HS2, HT3, HT4	CRD1 - 0200	3/8	7/8	15	286
RPH300H2 - HS2, HT3, HT4	CRJ3 - 0300	1/2	1 1/8	21	360
RPH400H2 - HS2, HT3, HT4	CRM3 - 0400	1/2	1 1/8	21	372
RPH500H2 - HS2, HT3, HT4	CRN5 - 0500	1/2	1 1/8	21	380
RPH150L5 - HS2, HT3	AH2480J	1/2	7/8	15	285
RPH200L5 - HS2, HT3	AH2511K	1/2	7/8	15	300
RPH050M6 - HS2	RS43C1E	3/8	5/8	5	195
RPH075M6 - HS2	RS64C1E	3/8	5/8	5	209
RPH100M6 - HS2, HT3	RS97C1E	3/8	5/8	7	263
RPH150M6 - HS2, HT3, HT4	CS10K6E	1/2	7/8	12	295
RPH200M6 - HS2, HT3	CS12K6E	1/2	7/8	12	289
RPH250M6 - HS2, HT3, HT4	CS14K6E	1/2	1 1/8	12	290
RPH300M6 - HS2, HT3, HT4	CS18K6E	1/2	1 1/8	16	360
RPH350M6 - HS2, HT3, HT4	CS20K6E	1/2	1 1/8	16	361
RPH400M6 - HS2, HT3, HT4	CS27K3E	1/2	1 1/8	16	368
RPH500M6 - HS2, HT3, HT4	CS33K3E	5/8	1 1/8	16	372
RPH050L6 - HS2	AJ2419Z	3/8	1/2	5	190
RPH075L6 - HS2	AJ2425Z	3/8	1/2	5	210
RPH099L6 - HS2, HT3	AWA2440Z	3/8	5/8	7	260
RPH151L6 - HS2, HT3, HT4	AWA2460Z	1/2	7/8	12	280
RPH201L6 - HS2, HT3, HT4	AVA2490Z	1/2	7/8	12	300
RPH290L6 - HS2, HT3, HT4	AVA2512Z	5/8	1 1/8	16	340

**50Hz Specifications are identical
to 60Hz shown above**



General Sales, Parts & Service Manufacturing & Engineering
135 Little Nine Drive, Morehead City, NC 28557
252-240-2829 • 1-800-24-BALLY • FAX: 252-240-0384
e-mail: ballysales@ballyrefboxes.com • www.ballyrefboxes.com

DISTRIBUTED BY: _____



Due to Manufacturer's policy of continuous product improvement, the Manufacturer reserves the right to make changes without notice.