



BES-Line Condensing Units

PRODUCT DATA & SPECIFICATIONS

Bulletin B40-BES-PDS-60-3

1079407

60
Hz

Indoor/Outdoor
Air-Cooled Semi-Hermetic
Condensing Units

1/2 to 7.5 HP -
High, Medium and Low
Temperature Refrigeration

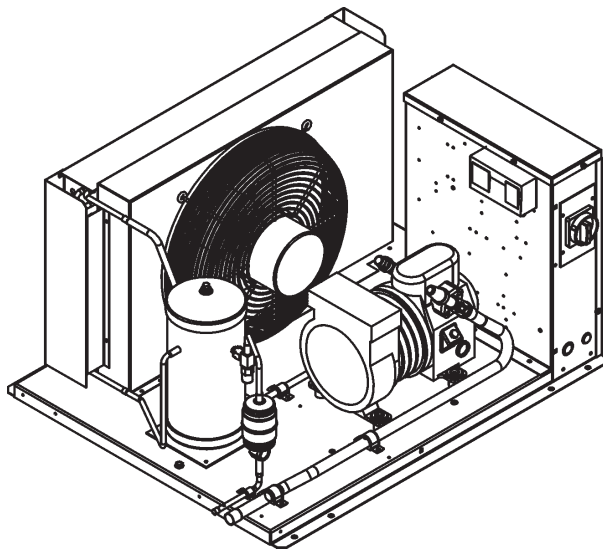

Indoor Unit

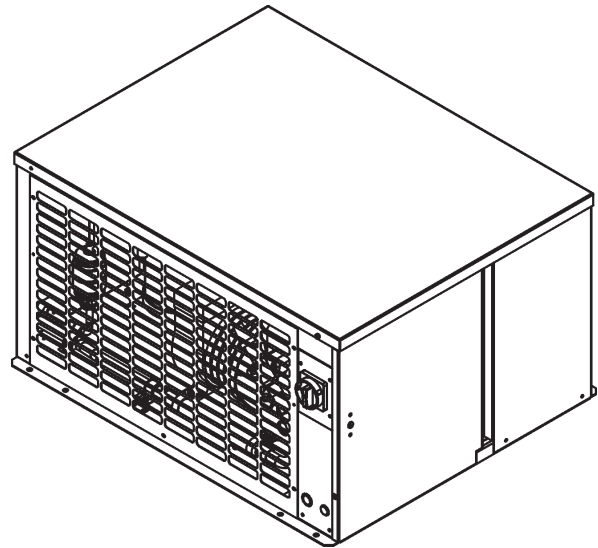

Outdoor Unit

CONTENTS

	Page
Nomenclature.....	2
Features.....	2 - 3
Capacity Data (Imperial and <i>Metric</i>).....	4 - 15
Electrical Data.....	16 - 20
Dimensional Data.....	21 - 22
Specifications.....	23 - 24
Wiring Diagrams.....	25 - 27

NOMENCLATURE

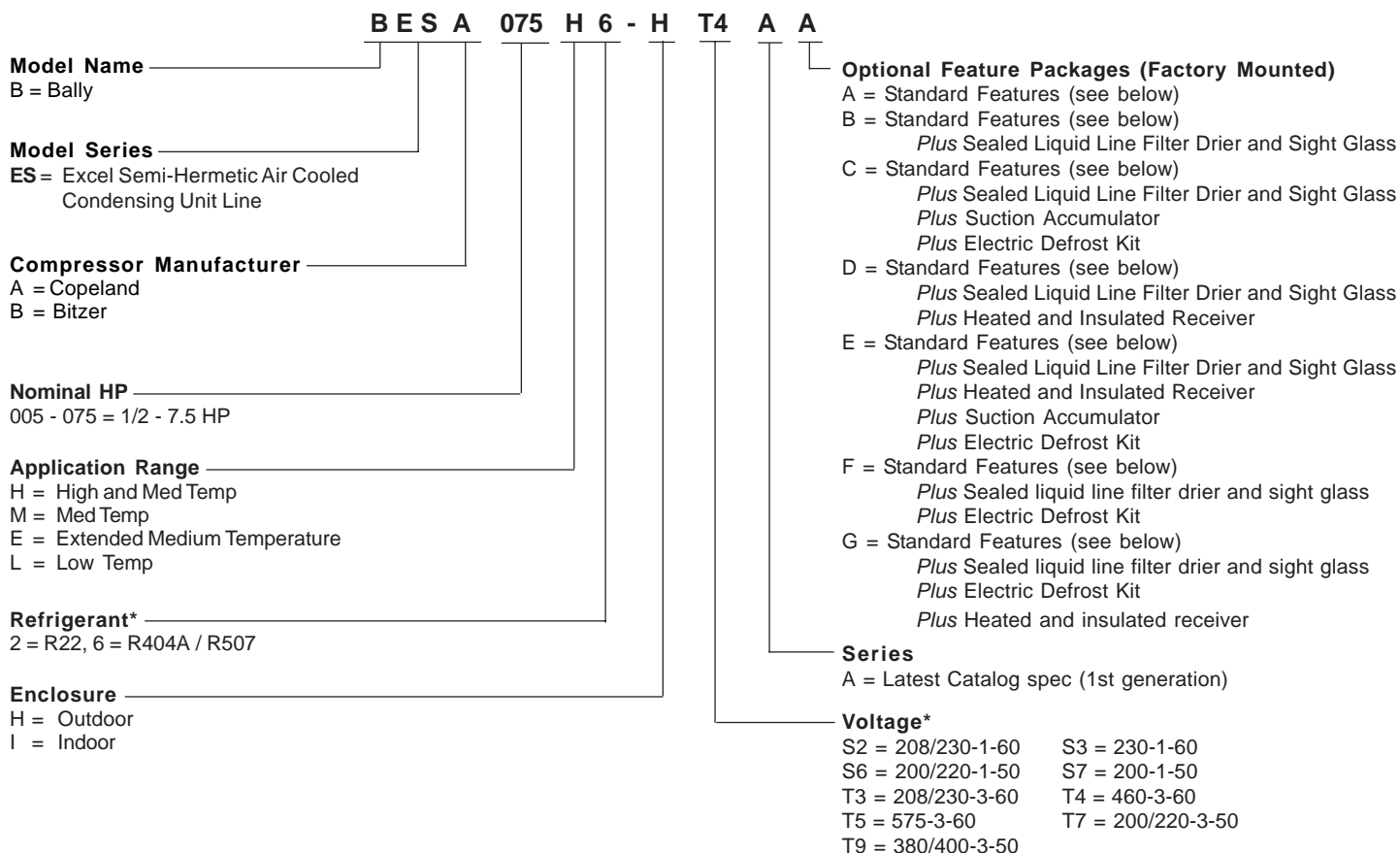

* subject to compressor availability

STANDARD FEATURES

Indoor Unit:

- Weatherproof electrical control box with compressor contactor and fused control circuit
- Solid mounted accessible semi-hermetic compressor up to 2 HP models
- Spring mounted accessible semi-hermetic compressor with suction and discharge vibration eliminator on 3 HP and over models
- High efficiency enhanced tube and fin condenser design
- Energy efficient PSC condenser fan motor
- Receiver with fusible plug and liquid shut off valve
- Adjustable dual high / low pressure control
- Oil Failure Control (where applicable)

- Suction service valve
- Pre-formed copper tubing
- Unit leak tested and shipped with Helium holding charge

Outdoor Unit: All Standard Features of Indoor Unit, Plus:

- Outdoor weather-resistant housing with removable hood
- Flooded head pressure control (non adjustable)
- Crankcase heater

OPTIONAL FEATURE PACKAGES (Factory Mounted)

Package A:

- Standard Features (see pg. 2)

Package B:

- Standard Features (see pg. 2)
- *Plus* Sealed Liquid Line Filter Drier & Sight Glass

Package C:

- Standard Features (see pg. 2)
- *Plus* Sealed Liquid Line Filter Drier & Sight Glass
- *Plus* Suction Accumulator
- *Plus* Electric Defrost Kit

Package D:

- Standard Features (see pg. 2)
- *Plus* Sealed Liquid Line Filter Drier & Sight Glass
- *Plus* Heated and Insulated Receiver

Package E:

- Standard Features (see pg. 2)
- *Plus* Sealed Liquid Line Filter Drier & Sight Glass
- *Plus* Heated and Insulated Receiver
- *Plus* Suction Accumulator
- *Plus* Electric Defrost Kit

Package F:

- Standard Features (see pg. 2)
- *Plus* Sealed liquid line filter drier and sight glass
- *Plus* Electric Defrost Kit

Package G:

- Standard Features (see pg. 2)
- *Plus* Sealed liquid line filter drier and sight glass
- *Plus* Electric Defrost Kit
- *Plus* Heated and insulated receiver

OPTIONAL FEATURES (Factory Mounted)

- Spring mounted accessible compressor with suction and discharge vibration eliminator on up 2 HP
- Suction accumulator
- Suction accumulator with boil-out coil
- Discharge line Check valve
- Oil separator
- Oil separator c/w oil return filter & solenoid valve
- Adjustable head pressure control valves
- Receiver inlet ball valve
- Heated and Insulated receiver
- Over-sized receiver
- Sealed liquid line filter drier & sight-glass
- Ball valve - liquid line (shipped loose)
- Insulated suction lines
- Leg Kits
- Discharge air hood
- Sub cooling circuit on 5 and 7.5 HP models
- Flex hoses - for all pressure controls (Dual Pressure, Oil switch, etc..)
- Liquid line solenoid valve-(with standard 230 volt coil)-shipped loose
- Compressor Circuit breaker
- Current sensing relay - for use with Oil safety control (where applicable)
- Defrost heater contactor c/w fuse block
- Evaporator Fan contactor c/w fuse block
- Disconnect switch
- Disconnect Fusing
- Pump down toggle switch
- Lock out control circuit -Liquid solenoid valve with separate HP and LP controls
- Hoffmann Speed control for condenser fan (replaces flooded valve)
- Sentronic oil failure control (where applicable)
- Time delay relay for compressor
- Mechanical Time Clock -Paragon 8145
- Electronic Time Clock
- Electronic Defrost Kit
- Electronic Voltage/Phase Monitor

CONDENSING UNIT MODEL	SATURATED SUCTION TEMPERATURE		AMBIENT TEMPERATURE ° F (° C)									
	° F	° C	85 (29.4)	90 (32.2)	95 (35.0)	100 (37.8)	105 (40.6)	110 (43.3)				
BESA005H2 Compressor Model HAG2-0050	45	(7.2)	7290 (2137)	7010 (2055)	6740 (1975)	6470 (1896)	6200 (1817)	5930 (1738)				
	40	(4.4)	6600 (1934)	6340 (1858)	6090 (1785)	5840 (1712)	5600 (1641)	5360 (1571)				
	35	(1.7)	5940 (1741)	5710 (1674)	5480 (1606)	5250 (1539)	5040 (1477)	4810 (1410)				
	30	(-1.1)	5340 (1565)	5120 (1501)	4910 (1439)	4710 (1380)	4510 (1322)	4310 (1263)				
	25	(-3.9)	4760 (1395)	4570 (1339)	4390 (1287)	4200 (1231)	4020 (1178)	3840 (1125)				
	20	(-6.7)	4230 (1240)	4060 (1190)	3890 (1140)	3730 (1093)	3560 (1043)	3410 (999)				
	15	(-9.4)	3750 (1099)	3590 (1052)	3450 (1011)	3300 (967)	3150 (923)	3010 (882)				
	10	(-12.2)	3320 (973)	3170 (929)	3040 (891)	2900 (850)	2780 (815)	2650 (777)				
	5	(-15)	2910 (853)	2790 (818)	2680 (785)	2550 (747)	2440 (715)	2330 (683)				
0	(-17.8)	2560 (750)	2460 (721)	2350 (689)	2250 (659)	2140 (627)	2040 (598)					
BESA008H2 Compressor Model KAN2-0075	45	(7.2)	11200 (3283)	10800 (3165)	10400 (3048)	9950 (2916)	9550 (2799)	9150 (2682)				
	40	(4.4)	10200 (2989)	9810 (2875)	9420 (2761)	9050 (2652)	8680 (2544)	8310 (2436)				
	35	(1.7)	9240 (2708)	8890 (2606)	8550 (2506)	8210 (2406)	7870 (2307)	7530 (2207)				
	30	(-1.1)	8340 (2444)	8020 (2351)	7700 (2257)	7400 (2169)	7090 (2078)	6790 (1990)				
	25	(-3.9)	7500 (2198)	7210 (2113)	6920 (2028)	6640 (1946)	6360 (1864)	6080 (1782)				
	20	(-6.7)	6710 (1967)	6440 (1887)	6180 (1811)	5920 (1735)	5680 (1665)	5420 (1589)				
	15	(-9.4)	5960 (1747)	5730 (1679)	5490 (1609)	5260 (1542)	5030 (1474)	4800 (1407)				
	10	(-12.2)	5280 (1547)	5070 (1486)	4850 (1421)	4650 (1363)	4440 (1301)	4220 (1237)				
	5	(-15)	4660 (1366)	4460 (1307)	4260 (1249)	4080 (1196)	3890 (1140)	3700 (1084)				
0	(-17.8)	4090 (1199)	3910 (1146)	3740 (1096)	3560 (1043)	3390 (994)	3210 (941)					
BESA010H2 Compressor Model KAR2-0100	45	(7.2)	15000 (4396)	14500 (4250)	14000 (4103)	13400 (3927)	12900 (3781)	12400 (3634)				
	40	(4.4)	13800 (4045)	13300 (3898)	12800 (3751)	12300 (3605)	11800 (3458)	11300 (3312)				
	35	(1.7)	12600 (3693)	12100 (3546)	11700 (3429)	11200 (3283)	10800 (3165)	10300 (3019)				
	30	(-1.1)	11400 (3341)	11000 (3224)	10600 (3107)	10200 (2989)	9740 (2855)	9330 (2734)				
	25	(-3.9)	10300 (3019)	9920 (2907)	9530 (2793)	9150 (2682)	8780 (2573)	8390 (2459)				
	20	(-6.7)	9250 (2711)	8900 (2608)	8550 (2506)	8200 (2403)	7860 (2304)	7510 (2201)				
	15	(-9.4)	8270 (2424)	7950 (2330)	7630 (2236)	7310 (2142)	6990 (2049)	6670 (1955)				
	10	(-12.2)	7350 (2154)	7070 (2072)	6780 (1987)	6480 (1899)	6190 (1814)	5900 (1729)				
	5	(-15)	6520 (1911)	6250 (1832)	5980 (1753)	5720 (1676)	5450 (1597)	5180 (1518)				
0	(-17.8)	5760 (1688)	5510 (1615)	5270 (1545)	5030 (1474)	4780 (1401)	4530 (1328)					
BESA015H2 Compressor Model KAGB-0150	45	(7.2)	19500 (5715)	18900 (5539)	18200 (5334)	17600 (5158)	17000 (4982)	16400 (4807)				
	40	(4.4)	17700 (5188)	17100 (5012)	16500 (4836)	15900 (4660)	15400 (4513)	14800 (4338)				
	35	(1.7)	16100 (4719)	15500 (4543)	14900 (4367)	14400 (4220)	13800 (4045)	13300 (3898)				
	30	(-1.1)	14500 (4250)	13900 (4074)	13400 (3927)	12900 (3781)	12400 (3634)	11900 (3488)				
	25	(-3.9)	12900 (3781)	12500 (3664)	12000 (3517)	11500 (3370)	11000 (3224)	10500 (3077)				
	20	(-6.7)	11500 (3370)	11100 (3253)	10600 (3107)	10200 (2989)	9750 (2858)	9330 (2734)				
	15	(-9.4)	10200 (2989)	9820 (2878)	9400 (2755)	9000 (2638)	8610 (2523)	8220 (2409)				
	10	(-12.2)	9040 (2649)	8670 (2541)	8300 (2433)	7940 (2327)	7580 (2222)	7240 (2122)				
	5	(-15)	8000 (2345)	7660 (2245)	7330 (2148)	7010 (2055)	6700 (1964)	6390 (1873)				
0	(-17.8)	7090 (2078)	6800 (1993)	6510 (1908)	6220 (1823)	5940 (1741)	5680 (1665)					
BESA020H2 Compressor Model KAKB-0200	45	(7.2)	26200 (7679)	25300 (7415)	24500 (7181)	23700 (6946)	22900 (6712)	22000 (6448)				
	40	(4.4)	23900 (7005)	23100 (6770)	22400 (6565)	21600 (6331)	20800 (6096)	20100 (5891)				
	35	(1.7)	21700 (6360)	21000 (6155)	20300 (5950)	19600 (5744)	18900 (5539)	18200 (5334)				
	30	(-1.1)	19600 (5744)	19000 (5569)	18400 (5393)	17800 (5217)	17100 (5012)	16500 (4836)				
	25	(-3.9)	17700 (5188)	17200 (5041)	16600 (4865)	16000 (4689)	15400 (4513)	14800 (4338)				
	20	(-6.7)	15900 (4660)	15400 (4513)	14900 (4367)	14400 (4220)	13800 (4045)	13300 (3898)				
	15	(-9.4)	14200 (4162)	13800 (4045)	13300 (3898)	12800 (3751)	12300 (3605)	11800 (3458)				
	10	(-12.2)	12600 (3693)	12200 (3576)	11700 (3429)	11300 (3312)	10900 (3195)	10400 (3048)				
	5	(-15)	11100 (3253)	10700 (3136)	10300 (3019)	9880 (2896)	9480 (2778)	9060 (2655)				
0	(-17.8)	9660 (2831)	9270 (2717)	8890 (2606)	8510 (2494)	8130 (2383)	7750 (2271)					

--- Outside Operating Range

CONDENSING UNIT MODEL	SATURATED SUCTION TEMPERATURE		AMBIENT TEMPERATURE ° F (° C)									
	° F	° C	85 (29.4)	90 (32.2)	95 (35.0)	100 (37.8)	105 (40.6)	110 (43.3)				
BESA030H2 Compressor Model ERF1-0310	45 (7.2)		43230 (12658)	41720 (12216)	40180 (11765)	38610 (11305)	---	---	---	---	---	---
	40 (4.4)		39460 (11554)	38070 (11147)	36650 (10731)	35200 (10307)	33730 (9876)	---	---	---	---	---
	35 (1.7)		35880 (10506)	34600 (10131)	33290 (9747)	31960 (9358)	30610 (8963)	29220 (8556)	---	---	---	---
	30 (-1.1)		32490 (9513)	31310 (9168)	30110 (8816)	28890 (8459)	27650 (8096)	26390 (7727)	---	---	---	---
	25 (-3.9)		29290 (8576)	28210 (8260)	27110 (7938)	26000 (7613)	24860 (7279)	23720 (6945)	---	---	---	---
	20 (-6.7)		26290 (7698)	25290 (7405)	24290 (7112)	23270 (6813)	22250 (6515)	21210 (6210)	---	---	---	---
	15 (-9.4)		23480 (6875)	22570 (6608)	21650 (6339)	20730 (6070)	19800 (5797)	18860 (5522)	---	---	---	---
	10 (-12.2)		20870 (6111)	20030 (5865)	19190 (5619)	18360 (5376)	17520 (5130)	16680 (4884)	---	---	---	---
5 (-15.0)		18450 (5402)	17680 (5177)	16920 (4954)	16160 (4732)	15410 (4512)	14650 (4290)	---	---	---	---	
BESA040H2 Compressor Model NRB2-0400	45 (7.2)		60630 (17752)	58280 (17064)	55990 (16394)	53780 (15747)	51660 (15126)	49620 (14529)	---	---	---	---
	40 (4.4)		55180 (16157)	53000 (15518)	50900 (14904)	48870 (14309)	46920 (13738)	45060 (13194)	---	---	---	---
	35 (1.7)		50000 (14640)	48000 (14054)	46060 (13486)	44200 (12942)	42420 (12421)	40730 (11926)	---	---	---	---
	30 (-1.1)		45100 (13205)	43250 (12664)	41470 (12142)	39770 (11645)	38140 (11167)	36600 (10716)	---	---	---	---
	25 (-3.9)		40450 (11844)	38750 (11346)	37110 (10866)	35550 (10409)	34060 (9973)	32660 (9563)	---	---	---	---
	20 (-6.7)		36050 (10555)	34480 (10096)	32970 (9654)	31530 (9232)	30180 (8837)	28900 (8462)	---	---	---	---
	15 (-9.4)		31880 (9334)	30430 (8910)	29030 (8500)	27710 (8113)	26460 (7747)	25290 (7405)	---	---	---	---
	10 (-12.2)		27930 (8178)	26570 (7780)	25280 (7402)	24050 (7042)	22890 (6702)	21810 (6386)	---	---	---	---
5 (-15.0)		24170 (7077)	22900 (6705)	21680 (6348)	20530 (6011)	19450 (5695)	18440 (5399)	---	---	---	---	
BESA050H2 Compressor Model 2DC3-0500	45 (7.2)		71050 (20803)	68710 (20118)	66370 (19433)	64030 (18748)	61690 (18063)	59350 (17378)	---	---	---	---
	40 (4.4)		64680 (18938)	62510 (18303)	60330 (17665)	58160 (17029)	56000 (16397)	53830 (15761)	---	---	---	---
	35 (1.7)		58670 (17179)	56660 (16590)	54650 (16002)	52640 (15413)	50630 (14824)	48630 (14239)	---	---	---	---
	30 (-1.1)		53030 (15527)	51160 (14980)	49300 (14435)	47440 (13890)	45580 (13346)	43720 (12801)	---	---	---	---
	25 (-3.9)		47730 (13975)	46000 (13469)	44280 (12965)	42550 (12459)	40830 (11955)	39110 (11451)	---	---	---	---
	20 (-6.7)		42770 (12523)	41160 (12052)	39560 (11583)	37960 (11115)	36360 (10646)	34770 (10181)	---	---	---	---
	15 (-9.4)		38120 (11162)	36630 (10725)	35140 (10289)	33650 (9853)	32160 (9416)	30680 (8983)	---	---	---	---
	10 (-12.2)		33770 (9888)	32380 (9481)	30990 (9074)	29600 (8667)	28210 (8260)	26830 (7856)	---	---	---	---
5 (-15.0)		29710 (8699)	28400 (8316)	27090 (7932)	25790 (7551)	24490 (7171)	23190 (6790)	---	---	---	---	
BESA051H2 Compressor Model 2DD3-0500	45 (7.2)		80180 (23477)	77560 (22710)	74930 (21940)	72320 (21175)	69690 (20405)	67070 (19638)	---	---	---	---
	40 (4.4)		73200 (21433)	70770 (20721)	68350 (20013)	65920 (19301)	63500 (18593)	61080 (17884)	---	---	---	---
	35 (1.7)		66590 (19498)	64350 (18842)	62110 (18186)	59870 (17530)	57640 (16877)	55400 (16221)	---	---	---	---
	30 (-1.1)		60350 (17670)	58280 (17064)	56210 (16458)	54150 (15855)	52090 (15252)	50040 (14652)	---	---	---	---
	25 (-3.9)		54470 (15949)	52560 (15390)	50650 (14830)	48750 (14274)	46850 (13718)	44960 (13164)	---	---	---	---
	20 (-6.7)		48940 (14330)	47180 (13814)	45410 (13296)	43650 (12781)	41900 (12268)	40160 (11759)	---	---	---	---
	15 (-9.4)		43750 (12810)	42110 (12330)	40480 (11853)	38850 (11375)	37240 (10904)	35620 (10430)	---	---	---	---
	10 (-12.2)		38880 (11384)	37350 (10936)	35840 (10494)	34330 (10052)	32830 (9613)	31340 (9176)	---	---	---	---
5 (-15.0)		34310 (10046)	32890 (9630)	31470 (9214)	30060 (8802)	28670 (8395)	27280 (7988)	---	---	---	---	
BESA075H2 Compressor Model 2DL3-0750	45 (7.2)		96090 (28135)	93020 (27236)	89940 (26334)	86840 (25427)	83730 (24516)	---	---	---	---	---
	40 (4.4)		88070 (25787)	85240 (24958)	82390 (24124)	79530 (23286)	76650 (22443)	73770 (21600)	---	---	---	---
	35 (1.7)		80460 (23559)	77860 (22797)	75230 (22027)	72590 (21254)	69940 (20478)	67280 (19700)	---	---	---	---
	30 (-1.1)		73260 (21451)	70860 (20748)	68440 (20039)	66010 (19328)	63580 (18616)	61140 (17902)	---	---	---	---
	25 (-3.9)		66430 (19451)	64230 (18807)	62010 (18157)	59780 (17504)	57540 (16848)	55310 (16195)	---	---	---	---
	20 (-6.7)		59970 (17559)	57950 (16968)	55910 (16370)	53870 (15773)	51820 (15173)	49770 (14573)	---	---	---	---
	15 (-9.4)		53850 (15767)	51990 (15223)	50120 (14675)	48250 (14128)	46380 (13580)	44510 (13033)	---	---	---	---
	10 (-12.2)		48040 (14066)	46330 (13565)	44620 (13065)	42900 (12561)	41190 (12060)	39480 (11560)	---	---	---	---
5 (-15.0)		42510 (12447)	40940 (11987)	39370 (11528)	37790 (11065)	36220 (10605)	34660 (10148)	---	---	---	---	
BESA076H2 Compressor Model 2DA3-0750	45 (7.2)		105240 (30814)	101800 (29807)	98350 (28797)	94870 (27778)	---	---	---	---	---	---
	40 (4.4)		96910 (28375)	93750 (27450)	90580 (26522)	87370 (25582)	84150 (24639)	---	---	---	---	---
	35 (1.7)		88900 (26030)	86000 (25181)	83080 (24326)	80130 (23462)	77150 (22590)	74160 (21714)	---	---	---	---
	30 (-1.1)		81210 (23778)	78540 (22997)	75850 (22209)	73130 (21412)	70390 (20610)	67600 (19793)	---	---	---	---
	25 (-3.9)		73830 (21617)	71370 (20897)	68890 (20171)	66380 (19436)	63820 (18686)	61230 (17928)	---	---	---	---
	20 (-6.7)		66770 (19550)	64490 (18883)	62180 (18206)	59840 (17521)	57460 (16824)	55040 (16116)	---	---	---	---
	15 (-9.4)		60010 (17571)	57890 (16950)	55730 (16318)	53530 (15674)	51290 (15018)	49000 (14347)	---	---	---	---
	10 (-12.2)		53550 (15679)	51550 (15094)	49500 (14494)	47420 (13885)	45280 (13258)	43100 (12620)	---	---	---	---
5 (-15.0)		47370 (13870)	45450 (13308)	43490 (12734)	41480 (12145)	39430 (11545)	37330 (10930)	---	---	---	---	

--- Outside Operating Range

CONDENSING UNIT MODEL	SATURATED SUCTION TEMPERATURE		AMBIENT TEMPERATURE ° F (° C)									
	° F	° C	85 (29.4)	90 (32.2)	95 (35.0)	100 (37.8)	105 (40.6)	110 (43.3)				
BESA005M2 Compressor Model HAJ1-0050	25	(-3.9)	5280 (1547)	5090 (1492)	4880 (1430)	4690 (1375)	4480 (1313)	4280 (1254)				
	20	(-6.7)	4740 (1389)	4550 (1334)	4370 (1281)	4180 (1225)	4010 (1175)	3820 (1120)				
	15	(-9.4)	4230 (1240)	4060 (1190)	3890 (1140)	3730 (1093)	3560 (1043)	3400 (996)				
	10	(-12.2)	3760 (1102)	3610 (1058)	3450 (1011)	3310 (970)	3150 (923)	3010 (882)				
	5	(-15)	3330 (976)	3180 (932)	3050 (894)	2910 (853)	2780 (815)	2650 (777)				
	0	(-17.8)	2930 (859)	2790 (818)	2670 (783)	2540 (744)	2430 (712)	2310 (677)				
BESA008M2 Compressor Model KAE2-0075	25	(-3.9)	8140 (2386)	7850 (2301)	7560 (2216)	7260 (2128)	6960 (2040)	6660 (1952)				
	20	(-6.7)	7300 (2140)	7030 (2060)	6760 (1981)	6490 (1902)	6220 (1823)	5940 (1741)				
	15	(-9.4)	6540 (1917)	6290 (1843)	6050 (1773)	5800 (1700)	5540 (1624)	5290 (1550)				
	10	(-12.2)	5850 (1715)	5620 (1647)	5400 (1583)	5170 (1515)	4940 (1448)	4710 (1380)				
	5	(-15)	5210 (1527)	5010 (1468)	4800 (1407)	4590 (1345)	4390 (1287)	4180 (1225)				
	0	(-17.8)	4600 (1348)	4420 (1295)	4230 (1240)	4060 (1190)	3870 (1134)	3690 (1081)				
BESA010M2 Compressor Model KAM2-0100	25	(-3.9)	12700 (3722)	12200 (3576)	11700 (3429)	11300 (3312)	10800 (3165)	10300 (3019)				
	20	(-6.7)	11500 (3370)	11000 (3224)	10600 (3107)	10100 (2960)	9700 (2843)	9280 (2720)				
	15	(-9.4)	10300 (3019)	9890 (2899)	9480 (2778)	9070 (2658)	8680 (2544)	8290 (2430)				
	10	(-12.2)	9190 (2693)	8820 (2585)	8450 (2477)	8080 (2368)	7710 (2260)	7360 (2157)				
	5	(-15)	8150 (2389)	7810 (2289)	7480 (2192)	7140 (2093)	6810 (1996)	6490 (1902)				
	0	(-17.8)	7150 (2096)	6860 (2011)	6560 (1923)	6250 (1832)	5960 (1747)	5680 (1665)				
BESA021M2 Compressor Model ERC1-0200	25	(-3.9)	19800 (5803)	19000 (5569)	18300 (5363)	17500 (5129)	16700 (4894)	16000 (4689)				
	20	(-6.7)	17600 (5158)	16900 (4953)	16200 (4748)	15500 (4543)	14900 (4367)	14200 (4162)				
	15	(-9.4)	15500 (4543)	14900 (4367)	14300 (4191)	13700 (4015)	13100 (3839)	12500 (3664)				
	10	(-12.2)	13600 (3986)	13100 (3839)	12600 (3693)	12000 (3517)	11500 (3370)	11000 (3224)				
	5	(-15)	11900 (3488)	11500 (3370)	11000 (3224)	10500 (3077)	10000 (2931)	9570 (2805)				
	0	(-17.8)	10400 (3048)	10000 (2931)	9570 (2805)	9150 (2682)	8710 (2553)	8290 (2430)				
BESA030M2 Compressor Model 3RA1-0310	25	(-3.9)	33350 (9765)	32170 (9419)	30990 (9074)	29800 (8725)	28590 (8371)	27370 (8014)				
	20	(-6.7)	30260 (8860)	29130 (8529)	28000 (8198)	26860 (7865)	25700 (7525)	24530 (7182)				
	15	(-9.4)	27280 (7988)	26220 (7677)	25150 (7364)	24060 (7045)	22960 (6723)	21850 (6398)				
	10	(-12.2)	24440 (7156)	23440 (6863)	22430 (6568)	21410 (6269)	20370 (5964)	19310 (5654)				
	5	(-15.0)	21710 (6357)	20790 (6087)	19850 (5812)	18900 (5534)	17930 (5250)	16940 (4960)				
	BESA050M2 Compressor Model NRM1-0500	25	(-3.9)	56240 (16467)	54310 (15902)	52400 (15343)	50480 (14781)	48540 (14213)	46580 (13639)			
20		(-6.7)	50650 (14830)	48900 (14318)	47150 (13806)	45400 (13293)	43630 (12775)	41850 (12254)				
15		(-9.4)	45480 (13317)	43880 (12848)	42280 (12380)	40690 (11914)	39090 (11446)	37460 (10968)				
10		(-12.2)	40700 (11917)	39250 (11492)	37800 (11068)	36350 (10643)	34900 (10219)	33420 (9785)				
5		(-15.0)	36320 (10634)	35000 (10248)	33690 (9864)	32380 (9481)	31060 (9094)	29720 (8702)				

--- Outside Operating Range

CONDENSING UNIT MODEL	SATURATED SUCTION TEMPERATURE		AMBIENT TEMPERATURE ° F (° C)					
	° F	° C	85 (29.4)	90 (32.2)	95 (35.0)	100 (37.8)	105 (40.6)	110 (43.3)
BESA050H6 Compressor Model 2DC3-050E	40 (4.4)		66260 (19401)	63070 (18467)	59920 (17545)	56790 (16628)	53690 (15720)	50630 (14824)
	35 (1.7)		60610 (17747)	57700 (16895)	54810 (16048)	51940 (15208)	49110 (14379)	46300 (13557)
	30 (-1.1)		55200 (16163)	52540 (15384)	49910 (14614)	47300 (13849)	44720 (13094)	42170 (12347)
	25 (-3.9)		50040 (14652)	47630 (13946)	45240 (13246)	42880 (12555)	40540 (11870)	38220 (11191)
	20 (-6.7)		45150 (13220)	42970 (12582)	40820 (11952)	38690 (11328)	36570 (10708)	34480 (10096)
	15 (-9.4)		40530 (11867)	38580 (11296)	36640 (10728)	34730 (10169)	32840 (9616)	30960 (9065)
	10 (-12.2)		36210 (10602)	34470 (10093)	32740 (9586)	31030 (9086)	29330 (8588)	27660 (8099)
	5 (-15.0)		32190 (9425)	30650 (8974)	29110 (8523)	27590 (8078)	26080 (7636)	24590 (7200)
	0 (-17.8)		28500 (8345)	27130 (7944)	25770 (7545)	24420 (7150)	23080 (6758)	21750 (6368)
-5 (-20.6)		25130 (7358)	23920 (7004)	22730 (6655)	21530 (6304)	20350 (5958)	19170 (5613)	
BESA051H6 Compressor Model 2DD3-050E	40 (4.4)		76190 (22308)	72660 (21275)	69110 (20235)	65540 (19190)	61960 (18142)	58370 (17091)
	35 (1.7)		70010 (20499)	66770 (19550)	63520 (18599)	60250 (17641)	56970 (16681)	53680 (15718)
	30 (-1.1)		64030 (18748)	61070 (17881)	58100 (17012)	55130 (16142)	52130 (15264)	49130 (14385)
	25 (-3.9)		58270 (17061)	55580 (16274)	52880 (15483)	50190 (14696)	47480 (13902)	44760 (13106)
	20 (-6.7)		52770 (15451)	50330 (14737)	47900 (14025)	45460 (13311)	43020 (12596)	40570 (11879)
	15 (-9.4)		47540 (13920)	45350 (13278)	43160 (12637)	40970 (11996)	38780 (11355)	36590 (10714)
	10 (-12.2)		42630 (12482)	40660 (11905)	38700 (11331)	36750 (10760)	34800 (10189)	32850 (9618)
	5 (-15.0)		38050 (11141)	36290 (10626)	34540 (10113)	32810 (9607)	31080 (9100)	29360 (8597)
	0 (-17.8)		33840 (9908)	32270 (9449)	30720 (8995)	29190 (8547)	27670 (8102)	26160 (7660)
-5 (-20.6)		30020 (8790)	28630 (8383)	27250 (7979)	25900 (7584)	24570 (7194)	23260 (6811)	
BESA075H6 Compressor Model 2DL3-075E	40 (4.4)		88330 (25863)	84230 (24663)	80140 (23465)	76060 (22270)	71980 (21076)	67910 (19884)
	35 (1.7)		81450 (23849)	77700 (22751)	73950 (21653)	70220 (20560)	66480 (19465)	62750 (18373)
	30 (-1.1)		74800 (21901)	71370 (20897)	67970 (19902)	64550 (18900)	61150 (17905)	57750 (16909)
	25 (-3.9)		68400 (20028)	65290 (19117)	62190 (18209)	59100 (17304)	56010 (16400)	52920 (15495)
	20 (-6.7)		62270 (18233)	59460 (17410)	56660 (16590)	53860 (15770)	51070 (14953)	48280 (14136)
	15 (-9.4)		56450 (16529)	53910 (15785)	51390 (15047)	48870 (14309)	46370 (13577)	43860 (12842)
	10 (-12.2)		50940 (14915)	48670 (14251)	46400 (13586)	44150 (12927)	41900 (12268)	39650 (11610)
	5 (-15.0)		45790 (13407)	43750 (12810)	41720 (12216)	39710 (11627)	37690 (11036)	35680 (10447)
	0 (-17.8)		41000 (12005)	39180 (11472)	37370 (10942)	35560 (10412)	33760 (9885)	31970 (9361)
-5 (-20.6)		36610 (10719)	34970 (10239)	33350 (9765)	31730 (9291)	30120 (8819)	28510 (8348)	
BESA076H6 Compressor Model 2DA3-075E	40 (4.4)		97240 (28472)	92670 (27134)	88130 (25804)	83600 (24478)	79090 (23158)	74600 (21843)
	35 (1.7)		90060 (26370)	85870 (25143)	81690 (23919)	77520 (22698)	73380 (21486)	69260 (20279)
	30 (-1.1)		83130 (24340)	79290 (23216)	75470 (22098)	71660 (20982)	67860 (19869)	64090 (18766)
	25 (-3.9)		76460 (22387)	72970 (21366)	69480 (20344)	66010 (19328)	62540 (18312)	59090 (17302)
	20 (-6.7)		70070 (20516)	66910 (19591)	63740 (18663)	60570 (17735)	57420 (16813)	54280 (15893)
	15 (-9.4)		63980 (18733)	61120 (17896)	58240 (17053)	55380 (16215)	52520 (15378)	49660 (14540)
	10 (-12.2)		58200 (17041)	55610 (16283)	53010 (15521)	50420 (14763)	47820 (14002)	45230 (13243)
	5 (-15.0)		52730 (15439)	50400 (14757)	48040 (14066)	45690 (13378)	43330 (12687)	40980 (11999)
	0 (-17.8)		47590 (13934)	45470 (13314)	43340 (12690)	41200 (12063)	39050 (11434)	36900 (10804)
-5 (-20.6)		42770 (12523)	40840 (11958)	38900 (11390)	36940 (10816)	34970 (10239)	32990 (9659)	

--- Outside Operating Range

CONDENSING UNIT MODEL	SATURATED SUCTION TEMPERATURE		AMBIENT TEMPERATURE ° F (° C)									
	° F	° C	85 (29.4)	90 (32.2)	95 (35.0)	100 (37.8)	105 (40.6)	110 (43.3)				
BESA005M6 Compressor Model HAJA-005E	25	-3.9	5650 (1656)	5350 (1568)	5040 (1477)	4740 (1389)	4450 (1304)	4160 (1219)				
	20	-6.7	5090 (1492)	4800 (1407)	4510 (1322)	4230 (1240)	3970 (1164)	3700 (1084)				
	15	-9.4	4570 (1339)	4310 (1263)	4050 (1187)	3800 (1114)	3550 (1040)	3310 (970)				
	10	-12.2	4110 (1205)	3870 (1134)	3640 (1067)	3410 (999)	3180 (932)	2970 (870)				
	5	-15	3690 (1081)	3470 (1017)	3250 (953)	3050 (894)	2850 (835)	2650 (777)				
	0	-17.8	3290 (964)	3090 (906)	2890 (847)	2710 (794)	2530 (742)	2360 (692)				
	-5	-20.6	2870 (841)	2710 (794)	2540 (744)	2380 (698)	2210 (648)	2060 (604)				
BESA010M6 Compressor Model KARB-010E	25	-3.9	10300 (3019)	9860 (2890)	9360 (2743)	8870 (2600)	8370 (2453)	7870 (2307)				
	20	-6.7	9530 (2793)	9070 (2658)	8620 (2526)	8160 (2392)	7690 (2254)	7230 (2119)				
	15	-9.4	8680 (2544)	8260 (2421)	7840 (2298)	7420 (2175)	6990 (2049)	6560 (1923)				
	10	-12.2	7840 (2298)	7450 (2183)	7070 (2072)	6670 (1955)	6280 (1841)	5880 (1723)				
	5	-15	7010 (2055)	6650 (1949)	6300 (1846)	5950 (1744)	5590 (1638)	5230 (1533)				
	0	-17.8	6240 (1829)	5920 (1735)	5600 (1641)	5280 (1547)	4960 (1454)	4650 (1363)				
	-5	-20.6	5550 (1627)	5260 (1542)	4990 (1462)	4700 (1377)	4420 (1295)	4130 (1210)				
BESA020M6 Compressor Model KAKA-020E	25	-3.9	17100 (5012)	16300 (4777)	15400 (4513)	14600 (4279)	13700 (4015)	12800 (3751)				
	20	-6.7	15700 (4601)	14900 (4367)	14100 (4132)	13300 (3898)	12500 (3664)	11800 (3458)				
	15	-9.4	14200 (4162)	13500 (3957)	12800 (3751)	12100 (3546)	11400 (3341)	10700 (3136)				
	10	-12.2	12700 (3722)	12100 (3546)	11400 (3341)	10800 (3165)	10200 (2989)	9570 (2805)				
	5	-15	11300 (3312)	10700 (3136)	10200 (2989)	9620 (2819)	9060 (2655)	8510 (2494)				
	0	-17.8	10100 (2960)	9560 (2802)	9050 (2652)	8550 (2506)	8040 (2356)	7550 (2213)				
	-5	-20.6	9040 (2649)	8580 (2515)	8120 (2380)	7650 (2242)	7200 (2110)	6750 (1978)				
BESA021M6 Compressor Model ERCA-021E	25	-3.9	21600 (6331)	20500 (6008)	19400 (5686)	18300 (5363)	17100 (5012)	16100 (4719)				
	20	-6.7	19600 (5744)	18500 (5422)	17500 (5129)	16500 (4836)	15500 (4543)	14500 (4250)				
	15	-9.4	17700 (5188)	16700 (4894)	15800 (4631)	14900 (4367)	14000 (4103)	13000 (3810)				
	10	-12.2	16000 (4689)	15100 (4426)	14200 (4162)	13400 (3927)	12500 (3664)	11700 (3429)				
	5	-15	14300 (4191)	13500 (3957)	12700 (3722)	12000 (3517)	11200 (3283)	10500 (3077)				
	0	-17.8	12700 (3722)	12000 (3517)	11300 (3312)	10600 (3107)	9910 (2904)	9230 (2705)				
	-5	-20.6	11100 (3253)	10500 (3077)	9860 (2890)	9230 (2705)	8610 (2523)	7990 (2342)				
BESA030M6 Compressor Model ERFA-031E	25	-3.9	31330 (9173)	29860 (8743)	28360 (8304)	26840 (7859)	25320 (7414)	23780 (6963)				
	20	-6.7	28410 (8318)	27070 (7926)	25700 (7525)	24320 (7121)	22930 (6714)	21530 (6304)				
	15	-9.4	25680 (7519)	24450 (7159)	23210 (6796)	21950 (6427)	20690 (6058)	19420 (5686)				
	10	-12.2	23130 (6772)	22010 (6445)	20880 (6114)	19730 (5777)	18580 (5440)	17430 (5104)				
	5	-15.0	20750 (6076)	19730 (5777)	18700 (5475)	17650 (5168)	16600 (4860)	15550 (4553)				
	0	-17.8	18520 (5423)	17590 (5150)	16640 (4872)	15680 (4591)	14720 (4310)	13770 (4032)				
	-5	-20.6	16440 (4814)	15570 (4559)	14700 (4304)	13810 (4044)	12930 (3786)	12050 (3528)				
BESA035M6 Compressor Model 3RAA-031E	25	-3.9	38950 (11405)	36840 (10787)	34730 (10169)	32640 (9557)	30550 (8945)	28480 (8339)				
	20	-6.7	35150 (10292)	33220 (9727)	31300 (9165)	29390 (8605)	27490 (8049)	25600 (7496)				
	15	-9.4	31550 (9238)	29790 (8723)	28050 (8213)	26320 (7706)	24590 (7200)	22880 (6699)				
	10	-12.2	28150 (8242)	26560 (7777)	24980 (7314)	23410 (6854)	21850 (6398)	20310 (5947)				
	5	-15.0	24970 (7311)	23530 (6890)	22100 (6471)	20680 (6055)	19270 (5642)	17870 (5232)				
	0	-17.8	21990 (6439)	20690 (6058)	19390 (5677)	18110 (5303)	16840 (4931)	15580 (4562)				
	-5	-20.6	19220 (5628)	18040 (5282)	16870 (4940)	15700 (4597)	14550 (4260)	13420 (3929)				
BESA040M6 Compressor Model NRB2-040E	25	-3.9	42870 (12552)	40600 (11888)	38350 (11229)	36110 (10573)	33900 (9926)	31710 (9285)				
	20	-6.7	38720 (11337)	36650 (10731)	34600 (10131)	32570 (9536)	30560 (8948)	28570 (8365)				
	15	-9.4	34820 (10195)	32930 (9642)	31070 (9097)	29230 (8559)	27410 (8026)	25610 (7499)				
	10	-12.2	31150 (9121)	29440 (8620)	27740 (8122)	26070 (7633)	24420 (7150)	22800 (6676)				
	5	-15.0	27700 (8111)	26140 (7654)	24600 (7203)	23080 (6758)	21580 (6319)	20110 (5888)				
	0	-17.8	24450 (7159)	23020 (6740)	21610 (6327)	20230 (5923)	18860 (5522)	17530 (5133)				
	-5	-20.6	21370 (6257)	20050 (5871)	18760 (5493)	17480 (5118)	16230 (4752)	15010 (4395)				

--- Outside Operating Range

CONDENSING UNIT MODEL	SATURATED SUCTION TEMPERATURE		AMBIENT TEMPERATURE ° F (° C)							
	° F	° C	85 (29.4)	90 (32.2)	95 (35.0)	100 (37.8)	105 (40.6)	110 (43.3)		
BESA005L6 Compressor Model KANB-005E	0	-17.8	4200 (1231)	3920 (1149)	3660 (1073)	3390 (994)	3130 (917)	2860 (838)		
	-5	-20.6	3690 (1081)	3430 (1005)	3190 (935)	2960 (868)	2720 (797)	2490 (730)		
	-10	-23.3	3190 (935)	2970 (870)	2750 (806)	2540 (744)	2340 (686)	2120 (621)		
	-15	-26.1	2730 (800)	2530 (742)	2340 (686)	2150 (630)	1970 (577)	1780 (522)		
	-20	-28.9	2310 (677)	2130 (624)	1960 (574)	1790 (525)	1630 (478)	1460 (428)		
	-25	-31.7	1930 (566)	1760 (516)	1610 (472)	1460 (428)	1320 (387)	1170 (343)		
	-30	-34.4	1580 (463)	1430 (419)	1300 (381)	1170 (343)	1040 (305)	910 (267)		
	-35	-37.2	1280 (375)	1150 (337)	1030 (302)	920 (270)	790 (232)	680 (199)		
	-40	-40.0	1030 (302)	920 (270)	800 (234)	700 (205)	590 (173)	480 (141)		
BESA008L6 Compressor Model KAMB-007E	0	-17.8	6440 (1887)	6130 (1797)	5820 (1706)	5500 (1612)	5180 (1518)	4850 (1421)		
	-5	-20.6	5760 (1688)	5470 (1603)	5190 (1521)	4910 (1439)	4620 (1354)	4320 (1266)		
	-10	-23.3	5090 (1492)	4830 (1416)	4580 (1342)	4330 (1269)	4070 (1193)	3790 (1111)		
	-15	-26.1	4450 (1304)	4220 (1237)	4000 (1172)	3770 (1105)	3520 (1032)	3280 (961)		
	-20	-28.9	3850 (1128)	3650 (1070)	3440 (1008)	3230 (947)	3020 (885)	2790 (818)		
	-25	-31.7	3320 (973)	3130 (917)	2950 (865)	2760 (809)	2560 (750)	2350 (689)		
	-30	-34.4	2860 (838)	2690 (788)	2520 (739)	2350 (689)	2160 (633)	1970 (577)		
	-35	-37.2	2480 (727)	2330 (683)	2170 (636)	2020 (592)	1840 (539)	1660 (487)		
	-40	-40.0	2210 (648)	2070 (607)	1930 (566)	1770 (519)	1610 (472)	1430 (419)		
BESA010L6 Compressor Model KAJB-010E	0	-17.8	8130 (2383)	7680 (2251)	7250 (2125)	6810 (1996)	6360 (1864)	5910 (1732)		
	-5	-20.6	7280 (2134)	6880 (2016)	6480 (1899)	6080 (1782)	5680 (1665)	5260 (1542)		
	-10	-23.3	6490 (1902)	6130 (1797)	5760 (1688)	5400 (1583)	5030 (1474)	4660 (1366)		
	-15	-26.1	5750 (1685)	5420 (1589)	5090 (1492)	4750 (1392)	4420 (1295)	4090 (1199)		
	-20	-28.9	5060 (1483)	4760 (1395)	4460 (1307)	4150 (1216)	3850 (1128)	3550 (1040)		
	-25	-31.7	4410 (1292)	4140 (1213)	3870 (1134)	3610 (1058)	3340 (979)	3070 (900)		
	-30	-34.4	3810 (1117)	3570 (1046)	3330 (976)	3090 (906)	2850 (835)	2620 (768)		
	-35	-37.2	3270 (958)	3050 (894)	2830 (829)	2620 (768)	2410 (706)	2190 (642)		
	-40	-40.0	2760 (809)	2560 (750)	2370 (695)	2180 (639)	2000 (586)	1810 (530)		
BESA015L6 Compressor Model KALB-015E	0	-17.8	12600 (3693)	12000 (3517)	11300 (3312)	10700 (3136)	10000 (2931)	9370 (2746)		
	-5	-20.6	11300 (3312)	10700 (3136)	10100 (2960)	9510 (2787)	8920 (2614)	8330 (2441)		
	-10	-23.3	10000 (2931)	9500 (2784)	8960 (2626)	8430 (2471)	7890 (2312)	7350 (2154)		
	-15	-26.1	8880 (2603)	8380 (2456)	7900 (2315)	7410 (2172)	6920 (2028)	6440 (1887)		
	-20	-28.9	7790 (2283)	7350 (2154)	6910 (2025)	6470 (1896)	6030 (1767)	5580 (1635)		
	-25	-31.7	6790 (1990)	6390 (1873)	5980 (1753)	5590 (1638)	5190 (1521)	4790 (1404)		
	-30	-34.4	5850 (1715)	5490 (1609)	5130 (1504)	4770 (1398)	4410 (1292)	4050 (1187)		
	-35	-37.2	5000 (1465)	4670 (1369)	4340 (1272)	4020 (1178)	3690 (1081)	3360 (985)		
	-40	-40.0	4200 (1231)	3900 (1143)	3610 (1058)	3310 (970)	3010 (882)	2700 (791)		
BESA020L6 Compressor Model EADB-021E	0	-17.8	14600 (4279)	13800 (4045)	12900 (3781)	12100 (3546)	11300 (3312)	10500 (3077)		
	-5	-20.6	13000 (3810)	12200 (3576)	11400 (3341)	10700 (3136)	9940 (2913)	9220 (2702)		
	-10	-23.3	11500 (3370)	10800 (3165)	10100 (2960)	9360 (2743)	8680 (2544)	8030 (2353)		
	-15	-26.1	10100 (2960)	9410 (2758)	8780 (2573)	8140 (2386)	7530 (2207)	6950 (2037)		
	-20	-28.9	8760 (2567)	8170 (2394)	7590 (2225)	7020 (2057)	6480 (1899)	5960 (1747)		
	-25	-31.7	7560 (2216)	7050 (2066)	6520 (1911)	6000 (1758)	5530 (1621)	5080 (1489)		
	-30	-34.4	6490 (1902)	6020 (1764)	5550 (1627)	5100 (1495)	4680 (1372)	4300 (1260)		
	-35	-37.2	5530 (1621)	5100 (1495)	4690 (1375)	4300 (1260)	3930 (1152)	3620 (1061)		
	-40	-40.0	4680 (1372)	4300 (1260)	3930 (1152)	3590 (1052)	3290 (964)	3040 (891)		
BESA021L6 Compressor Model EAVB-021E	0	-17.8	15900 (4660)	15100 (4426)	14200 (4162)	13400 (3927)	12600 (3693)	11800 (3458)		
	-5	-20.6	14300 (4191)	13500 (3957)	12800 (3751)	12000 (3517)	11300 (3312)	10600 (3107)		
	-10	-23.3	12700 (3722)	12000 (3517)	11400 (3341)	10700 (3136)	10100 (2960)	9400 (2755)		
	-15	-26.1	11200 (3283)	10600 (3107)	10000 (2931)	9430 (2764)	8840 (2591)	8250 (2418)		
	-20	-28.9	9820 (2878)	9290 (2723)	8770 (2570)	8220 (2409)	7670 (2248)	7120 (2087)		
	-25	-31.7	8550 (2506)	8080 (2368)	7580 (2222)	7080 (2075)	6560 (1923)	6040 (1770)		
	-30	-34.4	7400 (2169)	6960 (2040)	6500 (1905)	6020 (1764)	5510 (1615)	4990 (1462)		
	-35	-37.2	6390 (1873)	5960 (1747)	5510 (1615)	5030 (1474)	4520 (1325)	3990 (1169)		
	-40	-40.0	5510 (1615)	5090 (1492)	4620 (1354)	4120 (1208)	3590 (1052)	3050 (894)		

--- Outside Operating Range

CONDENSING UNIT MODEL	SATURATED SUCTION TEMPERATURE ° F ° C		AMBIENT TEMPERATURE ° F (° C)														
			85 (29.4)	90 (32.2)	95 (35.0)	100 (37.8)	105 (40.6)	110 (43.3)									
BESA030L6 Compressor Model LAHA-032E	0	-17.8)	26650 (7803)	25250 (7393)	23870 (6989)	22490 (6585)	21090 (6175)	19680 (5762)	0	-17.8)	29450 (8623)	27950 (8184)	26450 (7745)	24950 (7305)	23480 (6875)	22040 (6453)	
	-5	-20.6)	23750 (6954)	22470 (6579)	21190 (6204)	19900 (5827)	18610 (5449)	17300 (5065)	-5	-20.6)	26360 (7718)	25000 (7320)	23640 (6922)	22280 (6524)	20950 (6134)	19660 (5756)	
	-10	-23.3)	20990 (6146)	19810 (5800)	18630 (5455)	17440 (5106)	16250 (4758)	15030 (4401)	-10	-23.3)	23530 (6890)	22300 (6529)	21060 (6166)	19850 (5812)	18650 (5461)	17500 (5124)	
	-15	-26.1)	18360 (5376)	17280 (5060)	16200 (4743)	15110 (4424)	14020 (4105)	12900 (3777)	-15	-26.1)	20920 (6125)	19800 (5797)	18690 (5472)	17600 (5153)	16540 (4843)	15520 (4544)	
	-20	-28.9)	15870 (4647)	14890 (4360)	13920 (4076)	12930 (3786)	11930 (3493)	10910 (3194)	-20	-28.9)	18490 (5414)	17480 (5118)	16480 (4825)	15510 (4541)	14570 (4266)	13680 (4006)	
	-25	-31.7)	13550 (3967)	12670 (3710)	11780 (3449)	10900 (3192)	9990 (2925)	9060 (2653)	-25	-31.7)	16190 (4740)	15280 (4474)	14380 (4210)	13520 (3959)	12690 (3716)	11920 (3490)	
	-30	-34.4)	11380 (3332)	10600 (3104)	9820 (2875)	9020 (2641)	8210 (2404)	7370 (2158)	-30	-34.4)	13960 (4087)	13150 (3850)	12350 (3616)	11580 (3391)	10860 (3180)	10190 (2984)	
	-35	-37.2)	9400 (2752)	8710 (2550)	8030 (2351)	7330 (2146)	6610 (1935)	5860 (1716)	-35	-37.2)	11770 (3446)	11030 (3230)	10320 (3022)	9640 (2823)	9010 (2638)	8440 (2471)	
	-40	-40.0)	7600 (2225)	7020 (2055)	6420 (1880)	5820 (1704)	5190 (1520)	4520 (1323)	-40	-40.0)	9550 (2796)	8880 (2600)	8240 (2413)	7630 (2234)	7080 (2073)	6600 (1932)	
BESA031L6 Compressor Model NRD1-032E	0	-17.8)	---	---	---	---	---	---	---	0	-17.8)	---	---	---	---	---	---
	-5	-20.6)	---	---	---	---	---	---	---	-5	-20.6)	---	---	---	---	---	---
	-10	-23.3)	---	---	---	---	---	---	---	-10	-23.3)	---	---	---	---	---	---
	-15	-26.1)	---	---	---	---	---	---	---	-15	-26.1)	---	---	---	---	---	---
	-20	-28.9)	19310 (5654)	18220 (5335)	17140 (5019)	16070 (4705)	15030 (4401)	14010 (4102)	-20	-28.9)	16820 (4925)	15810 (4629)	14810 (4336)	13820 (4046)	12840 (3760)	11870 (3476)	
	-25	-31.7)	16820 (4925)	15810 (4629)	14810 (4336)	13820 (4046)	12840 (3760)	11870 (3476)	-25	-31.7)	14470 (4237)	13570 (3973)	12670 (3710)	11770 (3446)	10880 (3186)	9990 (2925)	
	-30	-34.4)	14470 (4237)	13570 (3973)	12670 (3710)	11770 (3446)	10880 (3186)	9990 (2925)	-30	-34.4)	12210 (3575)	11440 (3350)	10660 (3121)	9890 (2896)	9110 (2667)	8330 (2439)	
	-35	-37.2)	12210 (3575)	11440 (3350)	10660 (3121)	9890 (2896)	9110 (2667)	8330 (2439)	-35	-37.2)	9990 (2925)	9380 (2746)	8770 (2568)	8140 (2383)	7500 (2196)	6850 (2006)	
	-40	-40.0)	9990 (2925)	9380 (2746)	8770 (2568)	8140 (2383)	7500 (2196)	6850 (2006)	-40	-40.0)	---	---	---	---	---	---	
BESA032L6 Compressor Model LACA-032E	0	-17.8)	33210 (9724)	31580 (9247)	29980 (8778)	28400 (8316)	26820 (7853)	25260 (7396)	0	-17.8)	40500 (11858)	38610 (11305)	36730 (10755)	34850 (10204)	32980 (9657)	31100 (9106)	
	-5	-20.6)	29850 (8740)	28390 (8313)	26950 (7891)	25540 (7478)	24130 (7065)	22710 (6649)	-5	-20.6)	36420 (10664)	34720 (10166)	33020 (9668)	31320 (9170)	29620 (8673)	27920 (8175)	
	-10	-23.3)	26660 (7806)	25360 (7425)	24080 (7051)	22810 (6679)	21540 (6307)	20270 (5935)	-10	-23.3)	32580 (9539)	31050 (9091)	29510 (8641)	27980 (8193)	26440 (7742)	24910 (7294)	
	-15	-26.1)	23650 (6925)	22490 (6585)	21350 (6251)	20210 (5917)	19070 (5584)	17930 (5250)	-15	-26.1)	28970 (8482)	27590 (8078)	26210 (7674)	24830 (7270)	23440 (6863)	22060 (6459)	
	-20	-28.9)	20840 (6102)	19810 (5800)	18780 (5499)	17760 (5200)	16730 (4899)	15680 (4591)	-20	-28.9)	25600 (7496)	24350 (7130)	23110 (6767)	21870 (6404)	20620 (6038)	19370 (5672)	
	-25	-31.7)	18240 (5341)	17300 (5065)	16380 (4796)	15450 (4524)	14500 (4246)	13540 (3965)	-25	-31.7)	22450 (6573)	21330 (6245)	20220 (5920)	19090 (5590)	17970 (5262)	16850 (4934)	
	-30	-34.4)	15840 (4638)	14990 (4389)	14140 (4140)	13280 (3888)	12400 (3631)	11500 (3367)	-30	-34.4)	19540 (5721)	18530 (5426)	17520 (5130)	16510 (4834)	15490 (4535)	14470 (4237)	
	-35	-37.2)	13650 (3997)	12860 (3765)	12070 (3534)	11260 (3297)	10420 (3051)	9560 (2799)	-35	-37.2)	16850 (4934)	15930 (4664)	15010 (4395)	14090 (4126)	13160 (3853)	12230 (3581)	
	-40	-40.0)	11680 (3420)	10920 (3197)	10160 (2975)	9380 (2746)	8560 (2506)	7710 (2257)	-40	-40.0)	14380 (4210)	13540 (3965)	12690 (3716)	11840 (3467)	10990 (3218)	10130 (2966)	
BESA040L6 Compressor Model 2DL3-040E	0	-17.8)	40500 (11858)	38610 (11305)	36730 (10755)	34850 (10204)	32980 (9657)	31100 (9106)	0	-17.8)	50110 (14672)	47880 (14019)	45640 (13363)	43400 (12708)	41130 (12043)	38840 (11372)	
	-5	-20.6)	36420 (10664)	34720 (10166)	33020 (9668)	31320 (9170)	29620 (8673)	27920 (8175)	-5	-20.6)	45110 (13208)	43090 (12617)	41080 (12028)	39060 (11437)	37030 (10842)	34980 (10242)	
	-10	-23.3)	32580 (9539)	31050 (9091)	29510 (8641)	27980 (8193)	26440 (7742)	24910 (7294)	-10	-23.3)	40380 (11823)	38560 (11290)	36760 (10763)	34950 (10233)	33130 (9700)	31300 (9165)	
	-15	-26.1)	28970 (8482)	27590 (8078)	26210 (7674)	24830 (7270)	23440 (6863)	22060 (6459)	-15	-26.1)	35930 (10520)	34300 (10043)	32680 (9569)	31060 (9094)	29440 (8620)	27810 (8143)	
	-20	-28.9)	25600 (7496)	24350 (7130)	23110 (6767)	21870 (6404)	20620 (6038)	19370 (5672)	-20	-28.9)	31760 (9299)	30290 (8869)	28840 (8444)	27390 (8020)	25950 (7598)	24510 (7177)	
	-25	-31.7)	22450 (6573)	21330 (6245)	20220 (5920)	19090 (5590)	17970 (5262)	16850 (4934)	-25	-31.7)	27880 (8163)	26540 (7771)	25230 (7387)	23940 (7010)	22660 (6635)	21380 (6260)	
	-30	-34.4)	19540 (5721)	18530 (5426)	17520 (5130)	16510 (4834)	15490 (4535)	14470 (4237)	-30	-34.4)	24270 (7106)	23050 (6749)	21860 (6401)	20700 (6061)	19560 (5727)	18420 (5393)	
	-35	-37.2)	16850 (4934)	15930 (4664)	15010 (4395)	14090 (4126)	13160 (3853)	12230 (3581)	-35	-37.2)	20920 (6125)	19800 (5797)	18710 (5478)	17660 (5171)	16630 (4869)	15620 (4574)	
	-40	-40.0)	14380 (4210)	13540 (3965)	12690 (3716)	11840 (3467)	10990 (3218)	10130 (2966)	-40	-40.0)	17830 (5221)	16790 (4916)	15780 (4620)	14820 (4339)	13880 (4064)	12960 (3795)	
BESA060L6 Compressor Model 2DB3-060E	0	-17.8)	50110 (14672)	47880 (14019)	45640 (13363)	43400 (12708)	41130 (12043)	38840 (11372)	0	-17.8)	50110 (14672)	47880 (14019)	45640 (13363)	43400 (12708)	41130 (12043)	38840 (11372)	
	-5	-20.6)	45110 (13208)	43090 (12617)	41080 (12028)	39060 (11437)	37030 (10842)	34980 (10242)	-5	-20.6)	45110 (13208)	43090 (12617)	41080 (12028)	39060 (11437)	37030 (10842)	34980 (10242)	
	-10	-23.3)	40380 (11823)	38560 (11290)	36760 (10763)	34950 (10233)	33130 (9700)	31300 (9165)	-10	-23.3)	40380 (11823)	38560 (11290)	36760 (10763)	34950 (10233)	33130 (9700)	31300 (9165)	
	-15	-26.1)	35930 (10520)	34300 (10043)	32680 (9569)	31060 (9094)	29440 (8620)	27810 (8143)	-15	-26.1)	35930 (10520)	34300 (10043)	32680 (9569)	31060 (9094)	29440 (8620)	27810 (8143)	
	-20	-28.9)	31760 (9299)	30290 (8869)	28840 (8444)	27390 (8020)	25950 (7598)	24510 (7177)	-20	-28.9)	31760 (9299)	30290 (8869)	28840 (8444)	27390 (8020)	25950 (7598)	24510 (7177)	
	-25	-31.7)	27880 (8163)	26540 (7771)	25230 (7387)	23940 (7010)	22660 (6635)	21380 (6260)	-25	-31.7)	27880 (8163)	26540 (7771)	25230 (7387)	23940 (7010)	22660 (6635)	21380 (6260)	
	-30	-34.4)	24270 (7106)	23050 (6749)	21860 (6401)	20700 (6061)	19560 (5727)	18420 (5393)	-30	-34.4)	24270 (7106)	23050 (6749)	21860 (6401)	20700 (6061)	19560 (5727)	18420 (5393)	
	-35	-37.2)	20920 (6125)	19800 (5797)	18710 (5478)	17660 (5171)	16630 (4869)	15620 (4574)	-35	-37.2)	20920 (6125)	19800 (5797)	18710 (5478)	17660 (5171)	16630 (4869)	15620 (4574)	
	-40	-40.0)	17830 (5221)	16790 (4916)	15780 (4620)	14820 (4339)	13880 (4064)	12960 (3795)	-40	-40.0)	17830 (5221)	16790 (4916)	15780 (4620)	14820 (4339)	13880 (4064)	12960 (3795)	

--- Outside Operating Range

CONDENSING UNIT MODEL	SATURATED SUCTION TEMPERATURE		AMBIENT TEMPERATURE ° F (° C)							
	° F	° C	85 (29.4)	90 (32.2)	95 (35.0)	100 (37.8)	105 (40.6)	110 (43.3)		
BESA061L6 Compressor Model 3DA3A060E	0 (-17.8)		54630 (15996)	52300 (15313)	49990 (14637)	47670 (13958)	45330 (13273)	42960 (12579)		
	-5 (-20.6)		49260 (14423)	47180 (13814)	45110 (13208)	43040 (12602)	40930 (11984)	38780 (11355)		
	-10 (-23.3)		44170 (12933)	42320 (12391)	40480 (11853)	38620 (11308)	36730 (10755)	34780 (10184)		
	-15 (-26.1)		39380 (11530)	37740 (11050)	36100 (10570)	34430 (10081)	32720 (9580)	30960 (9065)		
	-20 (-28.9)		34900 (10219)	33440 (9791)	31980 (9364)	30480 (8925)	28940 (8474)	27320 (7999)		
	-25 (-31.7)		30750 (9004)	29450 (8623)	28140 (8239)	26790 (7844)	25370 (7428)	23880 (6992)		
	-30 (-34.4)		26940 (7888)	25770 (7545)	24580 (7197)	23340 (6834)	22030 (6450)	20640 (6043)		
	-35 (-37.2)		23470 (6872)	22410 (6562)	21310 (6240)	20160 (5903)	18930 (5543)	17600 (5153)		
	-40 (-40.0)		20360 (5961)	19370 (5672)	18330 (5367)	17230 (5045)	16040 (4697)	14760 (4322)		
BESA075L6 Compressor Model 3DB3A075E	0 (-17.8)		62460 (18288)	59770 (17501)	57110 (16722)	54480 (15952)	51870 (15188)	---	---	
	-5 (-20.6)		56450 (16529)	54060 (15829)	51690 (15135)	49340 (14447)	47010 (13765)	---	---	
	-10 (-23.3)		50770 (14865)	48660 (14248)	46550 (13630)	44460 (13018)	42380 (12409)	40300 (11800)		
	-15 (-26.1)		45440 (13305)	43560 (12754)	41700 (12210)	39830 (11662)	37960 (11115)	36090 (10567)		
	-20 (-28.9)		40440 (11841)	38780 (11355)	37120 (10869)	35450 (10380)	33760 (9885)	32070 (9390)		
	-25 (-31.7)		35780 (10476)	34300 (10043)	32810 (9607)	31300 (9165)	29760 (8714)	28210 (8260)		
	-30 (-34.4)		31450 (9209)	30120 (8819)	28760 (8421)	27370 (8014)	25950 (7598)	24500 (7174)		
	-35 (-37.2)		27430 (8032)	26210 (7674)	24950 (7305)	23650 (6925)	22300 (6529)	20920 (6125)		
	-40 (-40.0)		23720 (6945)	22560 (6606)	21360 (6254)	20100 (5885)	18800 (5505)	17440 (5106)		

--- Outside Operating Range

CONDENSING UNIT MODEL	SATURATED SUCTION TEMPERATURE		AMBIENT TEMPERATURE ° F (° C)							
	° F	° C	85 (29.4)	90 (32.2)	95 (35.0)	100 (37.8)	105 (40.6)	110 (43.3)		
BESB029H2 Compressor Model 2FC-3.2	45 (7.2)		35910 (10514)	34680 (10154)	33450 (9794)	32230 (9437)	31030 (9086)	29830 (8734)		
	40 (4.4)		32850 (9618)	31710 (9285)	30580 (8954)	29450 (8623)	28330 (8295)	27230 (7973)		
	35 (1.7)		29960 (8772)	28910 (8465)	27860 (8157)	26820 (7853)	25790 (7551)	24780 (7256)		
	30 (-1.1)		27240 (7976)	26270 (7692)	25300 (7408)	24350 (7130)	23400 (6852)	22470 (6579)		
	25 (-3.9)		24680 (7226)	23790 (6966)	22900 (6705)	22030 (6450)	21160 (6196)	20300 (5944)		
	20 (-6.7)		22280 (6524)	21460 (6283)	20650 (6046)	19850 (5812)	19060 (5581)	18270 (5349)		
	15 (-9.4)		20040 (5868)	19290 (5648)	18550 (5431)	17810 (5215)	17090 (5004)	16370 (4793)		
	10 (-12.2)		17940 (5253)	17260 (5054)	16580 (4855)	15910 (4658)	15250 (4465)	14600 (4275)		
5 (-15.0)		15990 (4682)	15370 (4500)	14750 (4319)	14140 (4140)	13540 (3965)	12940 (3789)			
BESB030H2 Compressor Model 2EC-3.2	45 (7.2)		42070 (12318)	40610 (11891)	39160 (11466)	37720 (11044)	36290 (10626)	34870 (10210)		
	40 (4.4)		38470 (11264)	37110 (10866)	35760 (10471)	34420 (10078)	33080 (9686)	31760 (9299)		
	35 (1.7)		35070 (10268)	33810 (9900)	32550 (9531)	31300 (9165)	30050 (8799)	28820 (8438)		
	30 (-1.1)		31860 (9329)	30690 (8986)	29520 (8643)	28360 (8304)	27200 (7964)	26050 (7627)		
	25 (-3.9)		28850 (8447)	27760 (8128)	26670 (7809)	25590 (7493)	24520 (7179)	23450 (6866)		
	20 (-6.7)		26020 (7619)	25010 (7323)	24000 (7027)	23000 (6734)	22000 (6442)	21000 (6149)		
	15 (-9.4)		23380 (6846)	22440 (6570)	21500 (6295)	20570 (6023)	19640 (5751)	18710 (5478)		
	10 (-12.2)		20910 (6122)	20040 (5868)	19170 (5613)	18300 (5358)	17430 (5104)	16570 (4852)		
5 (-15.0)		18610 (5449)	17800 (5212)	16990 (4975)	16180 (4738)	15370 (4500)	14570 (4266)			
BESB035H2 Compressor Model 2DC-3.2	45 (7.2)		51270 (15012)	49490 (14491)	47720 (13972)	45970 (13460)	44220 (12948)	42490 (12441)		
	40 (4.4)		46840 (13715)	45190 (13232)	43540 (12749)	41900 (12268)	40270 (11791)	38660 (11320)		
	35 (1.7)		42660 (12491)	41130 (12043)	39600 (11595)	38070 (11147)	36550 (10702)	35050 (10263)		
	30 (-1.1)		38730 (11340)	37310 (10924)	35880 (10506)	34460 (10090)	33050 (9677)	31660 (9270)		
	25 (-3.9)		35040 (10260)	33720 (9873)	32400 (9487)	31080 (9100)	29770 (8717)	28470 (8336)		
	20 (-6.7)		31580 (9247)	30350 (8886)	29130 (8529)	27900 (8169)	26690 (7815)	25480 (7461)		
	15 (-9.4)		28350 (8301)	27210 (7967)	26070 (7633)	24940 (7302)	23810 (6972)	22680 (6641)		
	10 (-12.2)		25330 (7417)	24280 (7109)	23220 (6799)	22170 (6491)	21120 (6184)	20070 (5876)		
5 (-15.0)		22530 (6597)	21550 (6310)	20570 (6023)	19590 (5736)	18600 (5446)	17630 (5162)			
BESB040H2 Compressor Model 2CC-4.2	45 (7.2)		60830 (17811)	58620 (17164)	56410 (16517)	54230 (15879)	52070 (15246)	49940 (14622)		
	40 (4.4)		55790 (16335)	53720 (15729)	51670 (15129)	49630 (14532)	47610 (13940)	45620 (13358)		
	35 (1.7)		51000 (14933)	49080 (14371)	47160 (13808)	45260 (13252)	43370 (12699)	41510 (12154)		
	30 (-1.1)		46480 (13609)	44680 (13082)	42900 (12561)	41130 (12043)	39370 (11528)	37630 (11018)		
	25 (-3.9)		42200 (12356)	40540 (11870)	38880 (11384)	37230 (10901)	35590 (10421)	33970 (9946)		
	20 (-6.7)		38180 (11179)	36640 (10728)	35090 (10274)	33560 (9826)	32040 (9381)	30530 (8939)		
	15 (-9.4)		34400 (10072)	32970 (9654)	31540 (9235)	30110 (8816)	28690 (8400)	27290 (7991)		
	10 (-12.2)		30870 (9039)	29540 (8649)	28210 (8260)	26880 (7870)	25560 (7484)	24250 (7100)		
5 (-15.0)		27570 (8072)	26330 (7709)	25100 (7349)	23860 (6986)	22630 (6626)	21400 (6266)			
BESB050H2 Compressor Model 4FC-5.2	45 (7.2)		71990 (21079)	69590 (20376)	67180 (19670)	64770 (18965)	62370 (18262)	59970 (17559)		
	40 (4.4)		65750 (19252)	63520 (18599)	61290 (17946)	59050 (17290)	56820 (16637)	54580 (15981)		
	35 (1.7)		59850 (17524)	57780 (16918)	55720 (16315)	53640 (15706)	51570 (15100)	49500 (14494)		
	30 (-1.1)		54290 (15896)	52380 (15337)	50470 (14778)	48550 (14215)	46630 (13653)	44710 (13091)		
	25 (-3.9)		49070 (14368)	47300 (13849)	45530 (13331)	43760 (12813)	41980 (12292)	40200 (11771)		
	20 (-6.7)		44160 (12930)	42530 (12453)	40900 (11976)	39260 (11495)	37620 (11015)	35980 (10535)		
	15 (-9.4)		39580 (11589)	38070 (11147)	36560 (10705)	35050 (10263)	33530 (9818)	32020 (9375)		
	10 (-12.2)		35300 (10336)	33910 (9929)	32510 (9519)	31110 (9109)	29710 (8699)	28310 (8289)		
5 (-15.0)		31310 (9168)	30030 (8793)	28740 (8415)	27440 (8034)	26150 (7657)	24850 (7276)			
BESB060H2 Compressor Model 4EC-6.2	45 (7.2)		85120 (24923)	82160 (24056)	79200 (23190)	76230 (22320)	73260 (21451)	70290 (20581)		
	40 (4.4)		77990 (22835)	75240 (22030)	72490 (21225)	69730 (20417)	66970 (19609)	64200 (18798)		
	35 (1.7)		71230 (20856)	68680 (20110)	66120 (19360)	63560 (18610)	60990 (17858)	58420 (17105)		
	30 (-1.1)		64830 (18982)	62460 (18288)	60090 (17594)	57710 (16897)	55330 (16201)	52940 (15501)		
	25 (-3.9)		58780 (17211)	56590 (16570)	54400 (15928)	52190 (15281)	49980 (14634)	47760 (13984)		
	20 (-6.7)		53090 (15545)	51070 (14953)	49040 (14359)	46990 (13759)	44940 (13158)	42890 (12558)		
	15 (-9.4)		47750 (13981)	45880 (13434)	43990 (12880)	42100 (12327)	40200 (11771)	38290 (11211)		
	10 (-12.2)		42750 (12517)	41010 (12008)	39270 (11498)	37510 (10983)	35750 (10468)	33970 (9946)		
5 (-15.0)		38070 (11147)	36470 (10678)	34850 (10204)	33220 (9727)	31580 (9247)	29930 (8764)			
BESB075H2 Compressor Model 4DC-7.2	45 (7.2)		99500 (29134)	96040 (28121)	92570 (27104)	89110 (26091)	85650 (25078)	82180 (24062)		
	40 (4.4)		91390 (26759)	88170 (25816)	84940 (24870)	81720 (23928)	78500 (22985)	75270 (22039)		
	35 (1.7)		83650 (24493)	80660 (23617)	77670 (22742)	74670 (21863)	71680 (20988)	68680 (20110)		
	30 (-1.1)		76290 (22338)	73520 (21527)	70750 (20716)	67970 (19902)	65190 (19088)	62410 (18274)		
	25 (-3.9)		69310 (20294)	66740 (19541)	64180 (18792)	61600 (18036)	59030 (17284)	56460 (16531)		
	20 (-6.7)		62710 (18361)	60340 (17668)	57960 (16971)	55580 (16274)	53200 (15577)	50810 (14877)		
	15 (-9.4)		56480 (16537)	54280 (15893)	52090 (15252)	49890 (14608)	47680 (13961)	45470 (13314)		
	10 (-12.2)		50620 (14822)	48600 (14230)	46560 (13633)	44530 (13038)	42490 (12441)	40440 (11841)		
5 (-15.0)		45130 (13214)	43260 (12667)	41380 (12116)	39490 (11563)	37600 (11009)	35700 (10453)			

**R404A/R507 - HIGH / MEDIUM
TEMPERATURE
CAPACITY BTU/H (WATTS)**

CONDENSING UNIT MODEL	SATURATED SUCTION TEMPERATURE		AMBIENT TEMPERATURE ° F (° C)									
	° F	° C	85 (29.4)	90 (32.2)	95 (35.0)	100 (37.8)	105 (40.6)	110 (43.3)				
BESB029H6 Compressor Model 2FC-3.2Y	40 (4.4)	34370 (10064)	32650 (9560)	30930 (9056)	29230 (8559)	27550 (8067)	25870 (7575)					
	35 (1.7)	31610 (9255)	30020 (8790)	28440 (8327)	26870 (7868)	25320 (7414)	23770 (6960)					
	30 (-1.1)	28980 (8485)	27510 (8055)	26060 (7630)	24620 (7209)	23190 (6790)	21780 (6377)					
	25 (-3.9)	26470 (7750)	25120 (7355)	23790 (6966)	22470 (6579)	21170 (6199)	19880 (5821)					
	20 (-6.7)	24090 (7054)	22860 (6693)	21640 (6336)	20440 (5985)	19250 (5636)	18070 (5291)					
	15 (-9.4)	21840 (6395)	20720 (6067)	19610 (5742)	18520 (5423)	17440 (5106)	16370 (4793)					
	10 (-12.2)	19710 (5771)	18690 (5472)	17690 (5180)	16700 (4890)	15720 (4603)	14750 (4319)					
	5 (-15.0)	17710 (5185)	16790 (4916)	15880 (4650)	14990 (4389)	14110 (4131)	13230 (3874)					
	0 (-17.8)	15840 (4638)	15010 (4395)	14190 (4155)	13380 (3918)	12580 (3683)	11790 (3452)					
-5 (-20.6)	14090 (4126)	13330 (3903)	12590 (3686)	11860 (3473)	11150 (3265)	10440 (3057)						
BESB030H6 Compressor Model 2EC-3.2Y	40 (4.4)	40900 (11976)	38890 (11387)	36890 (10801)	34890 (10216)	32900 (9633)	30910 (9050)					
	35 (1.7)	37700 (11039)	35830 (10491)	33980 (9949)	32140 (9411)	30300 (8872)	28470 (8336)					
	30 (-1.1)	34620 (10137)	32910 (9636)	31200 (9135)	29510 (8641)	27820 (8146)	26140 (7654)					
	25 (-3.9)	31680 (9276)	30110 (8816)	28550 (8359)	26990 (7903)	25450 (7452)	23910 (7001)					
	20 (-6.7)	28880 (8456)	27450 (8037)	26020 (7619)	24600 (7203)	23190 (6790)	21780 (6377)					
	15 (-9.4)	26230 (7680)	24920 (7297)	23620 (6916)	22320 (6535)	21040 (6161)	19760 (5786)					
	10 (-12.2)	23710 (6942)	22520 (6594)	21340 (6248)	20160 (5903)	19000 (5563)	17830 (5221)					
	5 (-15.0)	21340 (6248)	20260 (5932)	19190 (5619)	18120 (5306)	17060 (4995)	16010 (4688)					
	0 (-17.8)	19110 (5595)	18130 (5308)	17160 (5024)	16190 (4740)	15230 (4459)	14280 (4181)					
-5 (-20.6)	17020 (4983)	16130 (4723)	15250 (4465)	14370 (4208)	13500 (3953)	12640 (3701)						
BESB035H6 Compressor Model 2DC-3.2Y	40 (4.4)	49830 (14590)	47440 (13890)	45060 (13194)	42680 (12497)	40300 (11800)	37940 (11109)					
	35 (1.7)	45840 (13422)	43630 (12775)	41440 (12134)	39250 (11492)	37060 (10851)	34890 (10216)					
	30 (-1.1)	42020 (12303)	40000 (11712)	37980 (11121)	35980 (10535)	33970 (9946)	31970 (9361)					
	25 (-3.9)	38390 (11241)	36540 (10699)	34700 (10160)	32860 (9621)	31020 (9083)	29200 (8550)					
	20 (-6.7)	34950 (10233)	33260 (9739)	31580 (9247)	29900 (8755)	28230 (8266)	26560 (7777)					
	15 (-9.4)	31690 (9279)	30150 (8828)	28620 (8380)	27090 (7932)	25570 (7487)	24060 (7045)					
	10 (-12.2)	28610 (8377)	27210 (7967)	25820 (7560)	24440 (7156)	23060 (6752)	21690 (6351)					
	5 (-15.0)	25710 (7528)	24450 (7159)	23190 (6790)	21930 (6421)	20690 (6058)	19450 (5695)					
	0 (-17.8)	22990 (6731)	21850 (6398)	20710 (6064)	19570 (5730)	18450 (5402)	17330 (5074)					
-5 (-20.6)	20450 (5988)	19410 (5683)	18380 (5382)	17360 (5083)	16330 (4781)	15320 (4486)						
BESB040H6 Compressor Model 2CC-4.2Y	40 (4.4)	59280 (17357)	56400 (16514)	53520 (15671)	50660 (14833)	47780 (13990)	44920 (13153)					
	35 (1.7)	54700 (16016)	52050 (15240)	49390 (14461)	46750 (13688)	44110 (12915)	41470 (12142)					
	30 (-1.1)	50310 (14731)	47860 (14013)	45430 (13302)	43000 (12590)	40570 (11879)	38150 (11170)					
	25 (-3.9)	46090 (13495)	43860 (12842)	41630 (12189)	39400 (11536)	37180 (10886)	34970 (10239)					
	20 (-6.7)	42070 (12318)	40020 (11718)	37990 (11123)	35960 (10529)	33940 (9938)	31920 (9346)					
	15 (-9.4)	38240 (11197)	36370 (10649)	34520 (10107)	32680 (9569)	30840 (9030)	29010 (8494)					
	10 (-12.2)	34590 (10128)	32910 (9636)	31230 (9144)	29550 (8652)	27890 (8166)	26220 (7677)					
	5 (-15.0)	31150 (9121)	29620 (8673)	28100 (8228)	26590 (7786)	25080 (7343)	23580 (6904)					
	0 (-17.8)	27900 (8169)	26510 (7762)	25140 (7361)	23770 (6960)	22410 (6562)	21060 (6166)					
-5 (-20.6)	24850 (7276)	23590 (6907)	22340 (6541)	21110 (6181)	19880 (5821)	18660 (5464)						
BESB050H6 Compressor Model 4FC-5.2Y	40 (4.4)	68620 (20092)	65440 (19161)	62260 (18230)	59090 (17302)	55930 (16376)	52770 (15451)					
	35 (1.7)	63140 (18487)	60210 (17629)	57290 (16775)	54370 (15920)	51470 (15070)	48570 (14221)					
	30 (-1.1)	57910 (16956)	55220 (16168)	52540 (15384)	49870 (14602)	47210 (13823)	44550 (13044)					
	25 (-3.9)	52930 (15498)	50460 (14775)	48020 (14060)	45580 (13346)	43150 (12634)	40730 (11926)					
	20 (-6.7)	48190 (14110)	45950 (13454)	43720 (12801)	41500 (12151)	39290 (11504)	37090 (10860)					
	15 (-9.4)	43700 (12795)	41670 (12201)	39640 (11607)	37630 (11018)	35630 (10432)	33640 (9850)					
	10 (-12.2)	39460 (11554)	37620 (11015)	35790 (10479)	33980 (9949)	32170 (9419)	30370 (8892)					
	5 (-15.0)	35470 (10386)	33810 (9900)	32160 (9416)	30520 (8936)	28890 (8459)	27270 (7985)					
	0 (-17.8)	31720 (9288)	30220 (8848)	28740 (8415)	27260 (7982)	25790 (7551)	24340 (7127)					
-5 (-20.6)	28220 (8263)	26860 (7865)	25520 (7472)	24190 (7083)	22870 (6696)	21560 (6313)						

--- Outside Operating Range

R404A/R507 - HIGH / MEDIUM
TEMPERATURE (cont'd)
CAPACITY BTU/H (WATTS)

CONDENSING UNIT MODEL	SATURATED SUCTION TEMPERATURE ° F ° C	AMBIENT TEMPERATURE ° F (° C)									
		85 (29.4)	90 (32.2)	95 (35.0)	100 (37.8)	105 (40.6)	110 (43.3)				
BESB060H6 Compressor Model 4EC-6.2Y	40 (4.4)	79680 (23330)	75730 (22174)	71820 (21029)	67920 (19887)	---	---	---	---	---	
	35 (1.7)	73670 (21571)	70020 (20502)	66400 (19442)	62810 (18391)	59230 (17343)	55680 (16303)	---	---	---	
	30 (-1.1)	67880 (19875)	64530 (18894)	61190 (17916)	57890 (16950)	54600 (15987)	51340 (15032)	---	---	---	
	25 (-3.9)	62330 (18250)	59260 (17351)	56200 (16455)	53170 (15568)	50160 (14687)	47170 (13811)	---	---	---	
	20 (-6.7)	57020 (16695)	54210 (15873)	51420 (15056)	48660 (14248)	45910 (13442)	43190 (12646)	---	---	---	
	15 (-9.4)	51960 (15214)	49390 (14461)	46860 (13721)	44350 (12986)	41850 (12254)	39380 (11530)	---	---	---	
	10 (-12.2)	47140 (13803)	44820 (13123)	42520 (12450)	40240 (11782)	37980 (11121)	35740 (10465)	---	---	---	
	5 (-15.0)	42580 (12467)	40470 (11850)	38390 (11241)	36330 (10637)	34290 (10040)	32270 (9449)	---	---	---	
	0 (-17.8)	38260 (11203)	36360 (10646)	34480 (10096)	32620 (9551)	30780 (9012)	28960 (8479)	---	---	---	
	-5 (-20.6)	34200 (10014)	32480 (9510)	30780 (9012)	29110 (8523)	27450 (8037)	25810 (7557)	---	---	---	
BESB075H6 Compressor Model 4DC-7.2Y	40 (4.4)	93190 (27286)	88720 (25977)	---	---	---	---	---	---	---	
	35 (1.7)	86390 (25295)	82260 (24086)	78120 (22874)	---	---	---	---	---	---	
	30 (-1.1)	79810 (23368)	75990 (22250)	72200 (21140)	68400 (20028)	---	---	---	---	---	
	25 (-3.9)	73450 (21506)	69960 (20484)	66470 (19462)	63000 (18446)	59520 (17427)	---	---	---	---	
	20 (-6.7)	67340 (19717)	64150 (18783)	60960 (17849)	57790 (16921)	54620 (15993)	51450 (15065)	---	---	---	
	15 (-9.4)	61480 (18001)	58570 (17149)	55670 (16300)	52790 (15457)	49910 (14614)	47030 (13770)	---	---	---	
	10 (-12.2)	55870 (16359)	53230 (15586)	50610 (14819)	47990 (14051)	45380 (13287)	42780 (12526)	---	---	---	
	5 (-15.0)	50540 (14798)	48140 (14095)	45770 (13401)	43410 (12710)	41050 (12019)	38700 (11331)	---	---	---	
	0 (-17.8)	45460 (13311)	43310 (12681)	41160 (12052)	39030 (11428)	36910 (10807)	34790 (10187)	---	---	---	
	-5 (-20.6)	40670 (11908)	38720 (11337)	36780 (10769)	34860 (10207)	32950 (9648)	31050 (9091)	---	---	---	

--- Outside Operating Range



R404A/R507 - LOW TEMPERATURE CAPACITY BTU/H (WATTS)

60Hz

CONDENSING UNIT MODEL	SATURATED SUCTION TEMPERATURE ° F ° C		AMBIENT TEMPERATURE ° F (° C)											
			85 (29.4)	90 (32.2)	95 (35.0)	100 (37.8)	105 (40.6)	110 (43.3)						
BESB030L6 Compressor Model 2CC-3.2Y	0 (-17.8)		26700 (7818)	25300 (7408)	23920 (7004)	22550 (6603)	21190 (6204)	19860 (5815)						
	-5 (-20.6)		23870 (6989)	22600 (6617)	21350 (6251)	20110 (5888)	18890 (5531)	17680 (5177)						
	-10 (-23.3)		21190 (6204)	20050 (5871)	18920 (5540)	17800 (5212)	16700 (4890)	15610 (4571)						
	-15 (-26.1)		18670 (5467)	17640 (5165)	16620 (4866)	15620 (4574)	14630 (4284)	13650 (3997)						
	-20 (-28.9)		16310 (4776)	15390 (4506)	14470 (4237)	13570 (3973)	12670 (3710)	11790 (3452)						
	-25 (-31.7)		14110 (4131)	13280 (3888)	12450 (3645)	11640 (3408)	10830 (3171)	10040 (2940)						
	-30 (-34.4)		12070 (3534)	11320 (3314)	10580 (3098)	9840 (2881)	9110 (2667)	8400 (2460)						
	-35 (-37.2)		10190 (2984)	9510 (2785)	8830 (2585)	8160 (2389)	7500 (2196)	6840 (2003)						
	-40 (-40.0)		8470 (2480)	7840 (2296)	7210 (2111)	6600 (1932)	5990 (1754)	5390 (1578)						
BESB031L6 Compressor Model 4FC-3.2Y	0 (-17.8)		29100 (8520)	27660 (8099)	26230 (7680)	24820 (7267)	23410 (6854)	22020 (6447)						
	-5 (-20.6)		26060 (7630)	24750 (7247)	23460 (6869)	22180 (6494)	20910 (6122)	19660 (5756)						
	-10 (-23.3)		23180 (6787)	22000 (6442)	20840 (6102)	19680 (5762)	18540 (5429)	17410 (5098)						
	-15 (-26.1)		20470 (5994)	19400 (5680)	18350 (5373)	17320 (5071)	16300 (4773)	15290 (4477)						
	-20 (-28.9)		17920 (5247)	16960 (4966)	16020 (4691)	15090 (4418)	14180 (4152)	13280 (3888)						
	-25 (-31.7)		15540 (4550)	14680 (4298)	13830 (4049)	13000 (3806)	12190 (3569)	11380 (3332)						
	-30 (-34.4)		13320 (3900)	12540 (3672)	11790 (3452)	11040 (3233)	10310 (3019)	9600 (2811)						
	-35 (-37.2)		11250 (3294)	10560 (3092)	9880 (2893)	9210 (2697)	8550 (2503)	7910 (2316)						
	-40 (-40.0)		9350 (2738)	8720 (2553)	8100 (2372)	7490 (2193)	6910 (2023)	6330 (1853)						
BESB039L6 Compressor Model 4EC-4.2Y	0 (-17.8)		36360 (10646)	34500 (10102)	32660 (9563)	30850 (9033)	29060 (8509)	27300 (7993)						
	-5 (-20.6)		32630 (9554)	30940 (9059)	29280 (8573)	27640 (8093)	26020 (7619)	24420 (7150)						
	-10 (-23.3)		29100 (8520)	27570 (8072)	26070 (7633)	24590 (7200)	23140 (6775)	21700 (6354)						
	-15 (-26.1)		25770 (7545)	24400 (7144)	23040 (6746)	21720 (6360)	20410 (5976)	19120 (5598)						
	-20 (-28.9)		22650 (6632)	21420 (6272)	20200 (5915)	19010 (5566)	17840 (5224)	16690 (4887)						
	-25 (-31.7)		19730 (5777)	18620 (5452)	17530 (5133)	16470 (4822)	15420 (4515)	14390 (4213)						
	-30 (-34.4)		17010 (4981)	16020 (4691)	15040 (4404)	14080 (4123)	13140 (3847)	12220 (3578)						
	-35 (-37.2)		14490 (4243)	13590 (3979)	12710 (3721)	11850 (3470)	11010 (3224)	10190 (2984)						
	-40 (-40.0)		12150 (3558)	11340 (3320)	10550 (3089)	9770 (2861)	9010 (2638)	8260 (2419)						
BESB050L6 Compressor Model 4DC-5.2Y	0 (-17.8)		45220 (13240)	43020 (12596)	40850 (11961)	38690 (11328)	36560 (10705)	34440 (10084)						
	-5 (-20.6)		40450 (11844)	38470 (11264)	36500 (10687)	34560 (10119)	32630 (9554)	30730 (8998)						
	-10 (-23.3)		35960 (10529)	34180 (10008)	32410 (9490)	30660 (8977)	28930 (8471)	27220 (7970)						
	-15 (-26.1)		31750 (9296)	30140 (8825)	28560 (8362)	26990 (7903)	25450 (7452)	23920 (7004)						
	-20 (-28.9)		27810 (8143)	26370 (7721)	24950 (7305)	23550 (6895)	22170 (6491)	20810 (6093)						
	-25 (-31.7)		24140 (7068)	22850 (6690)	21580 (6319)	20330 (5953)	19100 (5592)	17900 (5241)						
	-30 (-34.4)		20730 (6070)	19570 (5730)	18440 (5399)	17320 (5071)	16230 (4752)	15160 (4439)						
	-35 (-37.2)		17580 (5147)	16540 (4843)	15520 (4544)	14520 (4251)	13540 (3965)	12590 (3686)						
	-40 (-40.0)		14670 (4295)	13730 (4020)	12810 (3751)	11910 (3487)	11030 (3230)	10170 (2978)						
BESB060L6 Compressor Model 4CC-6.2Y	0 (-17.8)		52670 (15422)	49980 (14634)	47330 (13858)	44720 (13094)	42160 (12344)	39640 (11607)						
	-5 (-20.6)		47380 (13873)	44940 (13158)	42550 (12459)	40190 (11768)	37880 (11091)	35610 (10427)						
	-10 (-23.3)		42350 (12400)	40150 (11756)	38000 (11126)	35890 (10509)	33810 (9900)	31780 (9305)						
	-15 (-26.1)		37600 (11009)	35620 (10430)	33690 (9864)	31800 (9311)	29940 (8766)	28130 (8236)						
	-20 (-28.9)		33110 (9695)	31350 (9179)	29620 (8673)	27930 (8178)	26280 (7695)	24660 (7220)						
	-25 (-31.7)		28910 (8465)	27330 (8002)	25790 (7551)	24280 (7109)	22820 (6682)	21380 (6260)						
	-30 (-34.4)		24980 (7314)	23570 (6901)	22190 (6497)	20850 (6105)	19550 (5724)	18280 (5352)						
	-35 (-37.2)		21320 (6242)	20060 (5874)	18820 (5510)	17630 (5162)	16470 (4822)	15340 (4492)						
	-40 (-40.0)		17920 (5247)	16790 (4916)	15680 (4591)	14610 (4278)	13570 (3973)	12550 (3675)						

--- Outside Operating Range

CONDENSING UNIT MODEL	COMPRESSOR MODEL NO.	POWER SUPPLY	COMPRESSOR		CONDENSER FAN MOTOR		MCA	MOP	
			RLA	LRA	QTY	FLA			
BESA005H2-*	S2A	HAG2-0050-CAV	208-230/1/60	4.0	22	1	0.5	5.5	15
	T3A	HAG1-0050-TAC	208-230/3/60	2.4	13	1	0.5	3.5	15
BESA008H2-*	S2A	KAN2-0075-CAV	208-230/1/60	6.1	36	1	0.5	8.1	15
	T3A	KAN1-0075-TAC	208-230/3/60	3.5	19.9	1	0.5	4.9	15
BESA010H2-*	S2A	KAR2-0100-CAV	208-230/1/60	7.4	40	1	0.5	9.8	15
	T3A	KAR1-0100-TAC	208-230/3/60	4.3	27	1	0.5	5.9	15
BESA015H2-*	S2A	KAGB-0150-CAV	208-230/1/60	9.6	55	1	1.1	13.1	20
	T3A	KAGA-0150-TAC	208-230/3/60	5.5	35.5	1	1.1	8.0	15
	T4A	KAGA-0150-TAD	460/3/60	2.5	18.2	1	0.6	3.7	15
BESA020H2-*	S2A	KAKB-0200-CAV	208-230/1/60	10.6	55	1	1.1	14.4	25
	T3A	KAKA-0200-TAC	208-230/3/60	6.8	50	1	1.1	9.6	15
	T4A	KAKA-0200-TAD	460/3/60	3.0	25	1	0.6	4.4	15
BESA030H2-*	HS3	ERF2-0310-CAB	230/1/60	17.0	86.0	1	2.1	23.4	40
	HT3	ERF1-0310-TAC	208-230/3/60	11.7	82.0	1	2.1	15.7	25
	HT4	ERF1-0310-TAD	460/3/60	6.4	41.0	1	0.9	8.9	15
BESA040H2-*	HT3	NRB2-0400-TFC	208-230/3/60	21.8	141.0	1	2.1	28.4	50
	HT4	NRB2-0400-TFD	460/3/60	11.3	62.5	1	0.9	15.0	25
BESA050H2-*	HS3	2DC3-0500-CFB	230/1/60	29.9	125.0	1	2.1	39.5	60
	HT3	2DC3-0500-TFC	208-230/3/60	22.3	120.0	1	2.1	30.0	50
	HT4	2DC3-0500-TFD	460/3/60	10.4	60.0	1	1.1	14.1	20
	HT5	2DC3-0500-TFE	575/3/60	7.7	49.0	1	0.9	10.5	15
BESA051H2-*	HT3	2DD3-0500-TFC	208-230/3/60	22.3	120.0	1	2.1	30.0	50
	HT4	2DD3-0500-TFD	460/3/60	10.5	60.0	1	1.1	14.2	20
	HT5	2DD3-0500-TFE	575/3/60	7.9	49.0	1	0.9	10.8	15
BESA075H2-*	HT3	2DL3-0750-TFC	208-230/3/60	31.6	169.0	1	2.1	41.6	70
	HT4	2DL3-0750-TFD	460/3/60	13.8	85.0	1	1.1	18.4	30
	HT5	2DL3-0750-TFE	575/3/60	13.2	67.0	1	0.9	17.4	30
BESA076H2-*	HT3	2DA3-0750-TFC	208-230/3/60	32.0	169.0	1	2.1	42.1	70
	HT4	2DA3-0750-TFD	460/3/60	14.1	85.0	1	1.1	18.7	30
	HT5	2DA3-0750-TFE	575/3/60	13.3	67.0	1	0.9	17.5	30
BESA005M2-*	S2A	HAJ2-0050-CAV	208-230/1/60	3.7	22	1	0.5	5.1	15
	T3A	HAJ1-0050-TAC	208-230/3/60	2.2	13	1	0.5	3.3	1
BESA008M2-*	S2A	KAE2-0075-CAV	208-230/1/60	5.4	36	1	0.5	7.3	15
	T3A	KAE1-0075-TAC	208-230/3/60	3.4	19.9	1	0.5	4.8	15
BESA010M2-*	S2A	KAM2-0100-CAV	208-230/1/60	7.5	40	1	0.5	9.9	15
	T3A	KAM1-0100-TAC	208-230/3/60	4.5	27	1	0.5	6.1	15
BESA021M2-*	S3A	ERC2-0200-CAB	230/1/60	10.9	58	1	1.1	14.7	25
	T3A	ERC1-0200-TAC	208-230/3/60	6.8	46	1	1.1	9.6	15
	T4A	ERC1-0200-TAD	460/3/60	3.6	23	1	0.6	5.1	15
	T5A	ERC1-0200-TAE	575/3/60	3.2	20	1	0.5	4.5	15
BESA030M2-*	HS3	3RA2-0310-CAB	230/1/60	17.8	86.0	1	2.1	24.4	40
	HT3	3RA1-0310-TAC	208-230/3/60	13.1	82.0	1	2.1	18.5	30
	HT4	3RA1-0310-TAD	460/3/60	6.6	41.0	1	1.1	9.4	15
BESA050M2-*	HT3	NRM1-0500-TFC	208-230/3/60	24.3	141.0	1	2.1	32.5	50
	HT4	NRM1-0500-TFD	460/3/60	12.1	62.5	1	1.1	16.2	25
	HT5	NRM1-0500-TFE	575/3/60	9.2	53.4	1	0.9	12.4	20

* I = Indoor, H = Outdoor. Above listed RLA value is based on UL rating method and may differ from published compressor RLA data.

CONDENSING UNIT MODEL	COMPRESSOR MODEL NO.	POWER SUPPLY	COMPRESSOR		CONDENSER FAN MOTOR		MCA	MOP	
			RLA	LRA	QTY	FLA			
BESA050H6-*	HT3	2DC3-050E-TFC	208-230/3/60	22.3	120.0	1	2.1	30.0	50
	HT4	2DC3-050E-TFD	460/3/60	10.4	60.0	1	1.1	14.1	20
	HT5	2DC3-050E-TFE	575/3/60	7.7	49.0	1	0.9	10.5	15
BESA051H6-*	HT3	2DD3-050E-TFC	208-230/3/60	22.3	120.0	1	2.1	30.0	50
	HT4	2DD3-050E-TFD	460/3/60	10.5	60.0	1	1.1	14.2	20
	HT5	2DD3-050E-TFE	575/3/60	7.9	49.0	1	0.9	10.8	15
BESA075H6-*	HT3	2DL3-075E-TFC	208-230/3/60	31.6	169.0	1	2.1	41.6	70
	HT4	2DL3-075E-TFD	460/3/60	13.8	85.0	1	1.1	18.4	30
	HT5	2DL3-075E-TFE	575/3/60	13.2	67.0	1	0.9	17.4	30
BESA076H6-*	HT3	2DA3-075E-TFC	208-230/3/60	32.0	169.0	1	2.1	42.1	70
	HT4	2DA3-075E-TFD	460/3/60	14.1	85.0	1	1.1	18.7	30
	HT5	2DA3-075E-TFE	575/3/60	13.3	67.0	1	0.9	17.5	30
BESA005M6-*	S2A	HAJB-005E-CAV	208-230/1/60	3.7	22	1	0.5	5.1	15
	T3A	HAJA-005E-TAC	208-230/3/60	2.2	13	1	0.5	3.3	15
BESA010M6-*	S2A	KARB-010E-CAV	208-230/1/60	7.4	40	1	0.5	9.8	15
	T3A	KARA-010E-TAC	208-230/3/60	4.3	27	1	0.5	5.9	15
BESA015M6-*	S2A	KAGB-010E-CAV	208-230/1/60	7.5	40	1	1.1	10.5	15
	T3A	KAGA-010E-TAC	208-230/3/60	4.3	27	1	1.1	6.5	15
	T4A	KAGA-011E-TAD	460/3/60	2.2	15	1	0.6	3.4	15
BESA020M6-*	S2A	KAKB-021E-CAV	208-230/1/60	10.6	55	1	1.1	14.4	25
	T3A	KAKA-020E-TAC	208-230/3/60	6.8	50	1	1.1	9.6	15
BESA021M6-*	T3A	ERCA-021E-TAC	208-230/3/60	8.8	46	1	1.1	12.1	20
	T4A	ERCA-020E-TAD	460/3/60	3.5	23	1	1.1	5.5	15
	T5A	ERCA-020E-TAE	575/3/60	3.1	20	1	0.6	4.5	15
BESA030M6-*	HS3	ERFB-031E-CAB	230/1/60	17.0	86.0	1	2.1	23.4	40
	HT3	ERFA-031E-TAC	208-230/3/60	12.4	82.0	1	2.1	17.6	30
	HT4	ERFA-031E-TAD	460/3/60	5.8	41.0	1	1.1	8.4	15
BESA035M6-*	HT3	3RAA-031E-TAC	208-230/3/60	14.2	82.0	1	2.1	19.9	30
	HT4	3RAA-031E-TAD	460/3/60	6.3	41.0	1	1.1	9.0	15
BESA040M6-*	HT3	NRB2-040E-TFC	208-230/3/60	21.8	141.0	1	2.1	29.4	50
	HT4	NRB2-040E-TFD	460/3/60	9.0	62.5	1	1.1	12.4	20

* I = Indoor, H = Outdoor. Above listed RLA value is based on UL rating method and may differ from published compressor RLA data.

CONDENSING UNIT MODEL	COMPRESSOR MODEL NO.	POWER SUPPLY	COMPRESSOR		CONDENSER FAN MOTOR		MCA	MOP	
			RLA	LRA	QTY	FLA			
BESA005L6-*	S2A	KANB-005E-CAV	208-230/1/60	3.6	24	1	0.5	5.0	15
	T3A	KANA-006E-TAC	208-230/3/60	2.2	13.2	1	0.5	3.3	15
BESA008L6-*	S2A	KAMB-007E-CAV	208-230/1/60	5.6	36	1	0.5	7.5	15
	T3A	KAMA-007E-TAC	208-230/3/60	3.2	19.9	1	0.5	4.5	15
BESA010L6-*	S2A	KAJB-010E-CAV	208-230/1/60	6.9	40	1	0.5	9.1	15
	T3A	KAJA-011E-TAC	208-230/3/60	4.6	27	1	0.5	6.3	15
BESA015L6-*	S2A	KALB-015E-CAV	208-230/1/60	9.9	55	1	1.1	13.5	20
	T3A	KALA-016E-TAC	208-230/3/60	6.6	50	1	1.1	9.4	15
	T4A	KALA-016E-TAD	460/3/60	3.4	25	1	0.6	4.9	15
BESA020L6-*	S3A	EADB-021E-CAB	230/1/60	10.0	58	1	1.1	13.6	20
	T3A	EADA-020E-TAC	208-230/3/60	6.8	46	1	1.1	9.6	15
BESA021L6-*	S3A	EAVB-021E-CAV	208-230/1/60	14.7	102	1	1.1	19.5	30
	T3A	EAVA-021E-TAC	208-230/3/60	7.4	50	1	1.1	10.4	15
	T4A	EAVA-021E-TAD	460/3/60	3.9	26.6	1	0.6	5.5	15
	T5A	EAVA-021E-TAE	575/3/60	3.1	20	1	0.5	4.4	15
BESA030L6-*	HS3	LAHB-032E-CAB	230/1/60	16.7	105.0	1	2.1	23.0	35
	HT3	LAHA-032E-TAC	208-230/3/60	12.8	112.0	1	2.1	18.1	30
	HT4	LAHA-032E-TAD	460/3/60	6.0	56.0	1	1.1	8.6	15
	HT5	LAHA-032E-TAE	575/3/60	4.1	30.0	1	0.9	6.0	15
BESA031L6-*	HS3	NRD1-040E-CFB	230/1/60	27.7	115.0	1	2.1	36.7	60
	HT3	NRD1-032E-TFC	208-230/3/60	16.3	82.0	1	2.1	22.5	35
	HT4	NRD1-032E-TFD	460/3/60	8.4	41.0	1	1.1	11.6	20
BESA032L6-*	HS3	LACB-032E-CAB	230/1/60	15.5	105.0	1	2.1	21.5	35
	HT3	LACA-032E-TAC	208-230/3/60	12.8	112.0	1	2.1	18.1	30
	HT4	LACA-032E-TAD	460/3/60	6.0	56.0	1	1.1	8.6	15
BESA035L6-*	HT3	2DF3-030E-TFC	208-230/3/60	16.8	102.0	1	2.1	23.1	35
	HT4	2DF3-030E-TFD	460/3/60	8.1	52.0	1	1.1	11.2	15
	HT5	2DF3-030E-TFE	575/3/60	6.7	41.0	1	0.9	9.3	15
BESA040L6-*	HT3	2DL3-040E-TFC	208-230/3/60	26.3	161.0	1	2.1	35.0	60
	HT4	2DL3-040E-TFD	460/3/60	10.2	60.0	1	1.1	13.9	20
	HT5	2DL3-040E-TFE	575/3/60	7.7	49.0	1	0.9	10.5	15
BESA060L6-*	HT3	2DB3-060E-TFC	208-230/3/60	28.2	161.0	1	2.1	37.4	60
	HT4	2DB3-060E-TFD	460/3/60	13.3	80.0	1	1.1	17.7	30
	HT5	2DB3-060E-TFE	575/3/60	9.6	63.0	1	0.9	12.9	20
BESA061L6-*	HT3	3DA3A060E-TFC	208-230/3/60	30.3	150.0	1	2.1	40.0	70
	HT4	3DA3A060E-TFD	460/3/60	13.7	77.0	1	1.1	18.2	30
	HT5	3DA3A060E-TFE	575/3/60	10.5	62.0	1	0.9	14.0	20
BESA075L6-*	HT3	3DB3A075E-TFC	208-230/3/60	31.5	161.0	1	2.1	41.5	70
	HT4	3DB3A075E-TFD	460/3/60	16.1	83.0	1	1.1	21.2	35
	HT5	3DB3A075E-TFE	575/3/60	11.0	67.0	1	0.9	14.7	25

* I = Indoor, H = Outdoor. Above listed RLA value is based on UL rating method and may differ from published compressor RLA data.

CONDENSING UNIT MODEL	COMPRESSOR MODEL NO.	POWER SUPPLY	COMPRESSOR		CONDENSER FAN MOTOR		MCA	MOP
			RLA	LRA	QTY	FLA		
BESB029H2-*	2FC-3.2	208-230/3/60	11.5	60.0	1	2.1	16.5	25
		460/3/60	5.5	27.5	1	1.1	8.0	15
		575/3/60	4.5	19.0	1	0.9	6.5	15
BESB030H2-*	2EC-3.2	208-230/1/60	24.0	109.0	1	2.1	32.1	50
		208-230/3/60	14.2	97.0	1	2.1	19.9	30
		460/3/60	6.7	39.5	1	1.1	9.5	15
		575/3/60	5.4	28.5	1	0.9	7.7	15
BESB035H2-*	2DC-3.2	208-230/1/60	25.0	113.0	1	2.1	33.4	50
		208-230/3/60	15.5	97.0	1	2.1	21.5	35
		460/3/60	7.5	39.5	1	1.1	10.5	15
		575/3/60	5.2	28.5	1	0.9	7.4	15
BESB040H2-*	2CC-4.2	208-230/3/60	18.5	115.5	1	2.1	25.2	40
		460/3/60	8.3	47.5	1	1.1	11.5	20
		575/3/60	6.7	34.0	1	0.9	9.3	15
BESB050H2-*	4FC-5.2	208-230/3/60	24.5	163.0	1	2.1	32.7	50
		460/3/60	13.5	66.5	1	1.1	18.0	30
		575/3/60	9.0	48.0	1	0.9	12.2	20
BESB060H2-*	4EC-6.2	208-230/3/60	28.5	163.0	1	2.1	37.7	60
		460/3/60	13.8	66.5	1	1.1	18.4	30
		575/3/60	9.6	48.0	1	0.9	12.9	20
BESB075H2-*	4DC-7.2	208-230/3/60	31.5	215.0	1	2.1	41.5	70
		460/3/60	15.5	88.0	1	1.1	20.5	35
		575/3/60	11.3	63.5	1	0.9	15.0	25
BESB029H6-*	2FC-3.2Y	208-230/3/60	11.5	60.0	1	2.1	16.5	25
		460/3/60	5.5	27.5	1	1.1	8.0	15
		575/3/60	4.5	19.0	1	0.9	6.5	15
BESB030H6-*	2EC-3.2Y	208-230/1/60	24.0	109.0	1	2.1	32.1	50
		208-230/3/60	14.2	97.0	1	2.1	19.9	30
		460/3/60	6.7	39.5	1	1.1	9.5	15
		575/3/60	5.4	28.5	1	0.9	7.7	15
BESB035H6-*	2DC-3.2Y	208-230/1/60	25.0	113.0	1	2.1	33.4	50
		208-230/3/60	15.5	97.0	1	2.1	21.5	35
		460/3/60	7.5	39.5	1	1.1	10.5	15
		575/3/60	5.2	28.5	1	0.9	7.4	15
BESB040H6-*	2CC-4.2Y	208-230/3/60	18.5	115.5	1	2.1	25.2	40
		460/3/60	8.3	47.5	1	1.1	11.5	20
		575/3/60	6.7	34.0	1	0.9	9.3	15
BESB050H6-*	4FC-5.2Y	208-230/3/60	24.5	163.0	1	2.1	32.7	50
		460/3/60	13.5	66.5	1	1.1	18.0	30
		575/3/60	9.0	48.0	1	0.9	12.2	20
BESB060H6-*	4EC-6.2Y	208-230/3/60	28.5	163.0	1	2.1	37.7	60
		460/3/60	13.8	66.5	1	1.1	18.4	30
		575/3/60	9.6	48.0	1	0.9	12.9	20
BESB075H6-*	4DC-7.2Y	208-230/3/60	31.5	215.0	1	2.1	41.5	70
		460/3/60	15.5	88.0	1	1.1	20.5	35
		575/3/60	11.3	63.5	1	0.9	15.0	25

* I = Indoor, H = Outdoor. Above listed RLA value is based on UL rating method and may differ from published compressor RLA data.

CONDENSING UNIT MODEL	COMPRESSOR MODEL NO.	POWER SUPPLY	COMPRESSOR		CONDENSER FAN MOTOR		MCA	MOP
			RLA	LRA	QTY	FLA		
BESB030L6-*	2CC-3.2Y	208-230/1/60	22.0	115.0	1	2.1	29.6	50
		208-230/3/60	13.8	97.0	1	2.1	19.4	30
		460/3/60	6.5	39.5	1	1.1	9.2	15
		575/3/60	5.2	28.5	1	0.9	7.4	15
BESB031L6-*	4FC-3.2Y	208-230/3/60	18.5	115.5	1	2.1	25.2	40
		460/3/60	8.2	47.5	1	1.1	11.4	20
		575/3/60	6.3	34.0	1	0.9	8.8	15
BESB039L6-*	4EC-4.2Y	208-230/3/60	20.5	142.0	1	2.1	27.7	45
		460/3/60	9.5	58.0	1	1.1	13.0	20
		575/3/60	7.6	51.5	1	0.9	10.4	15
BESB050L6-*	4DC-5.2Y	208-230/3/60	21.0	163.0	1	2.1	28.4	45
		460/3/60	11.0	66.5	1	1.1	14.9	25
		575/3/60	9.2	48.0	1	0.9	12.4	20
BESB060L6-*	4CC-6.2Y	208-230/3/60	25.5	215.0	1	2.1	34.0	50
		460/3/60	14.5	88.0	1	1.1	19.2	30
		575/3/60	11.5	63.5	1	0.9	15.3	25

* I = Indoor, H = Outdoor. Above listed RLA value is based on UL rating method and may differ from published compressor RLA data.

DIMENSIONAL DATA (Models 005 to 029)

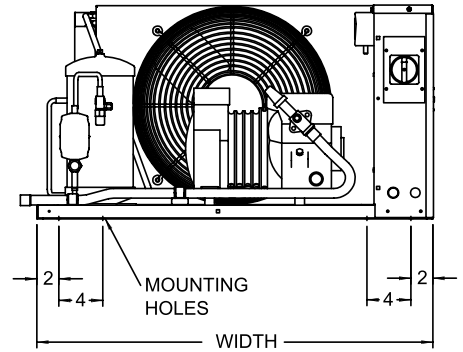
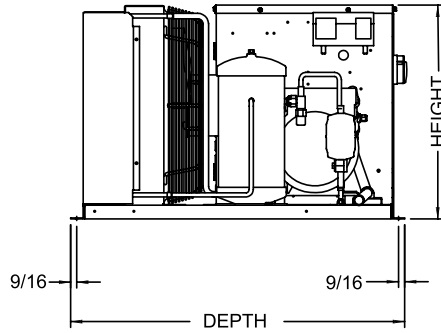
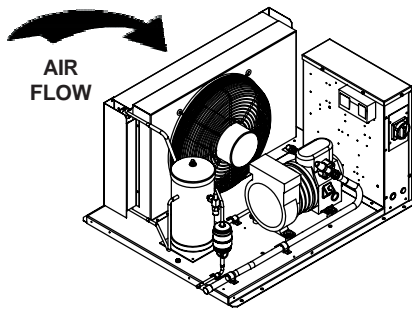

INDOOR DIMENSIONS

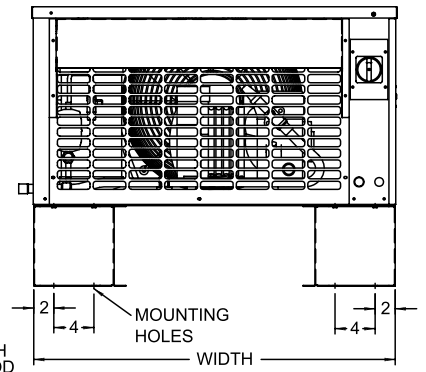
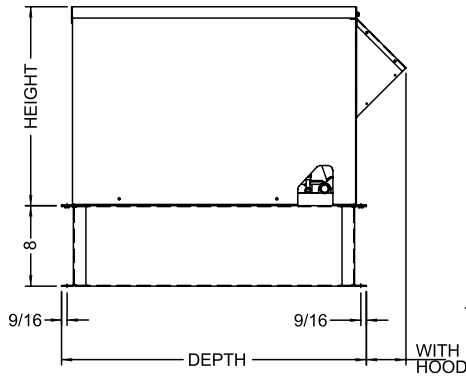
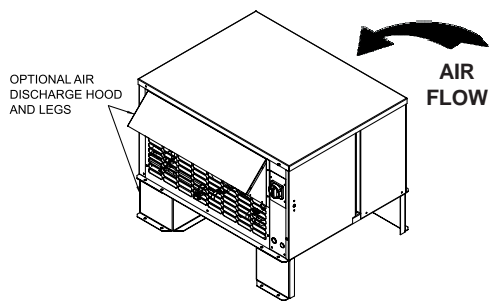

OUTDOOR DIMENSIONS

CONDENSING UNIT MODEL	WIDTH		DEPTH				HEIGHT*	
			Base		With Hood			
	Inches	mm	Inches	mm	Inches	mm	Inches	mm
BES A 005	24 7/8	632	30 3/8	772	34 3/8	873	16 7/8	429
BES A 008	24 7/8	632	30 3/8	772	34 3/8	873	16 7/8	429
BES A 010	24 7/8	632	30 3/8	772	34 3/8	873	16 7/8	429
BES A 015	36 3/8	924	30 3/8	772	34 3/8	873	19 7/8	505
BES A 020	36 3/8	924	30 3/8	772	34 3/8	873	19 7/8	505
BES A 021	36 3/8	924	30 3/8	772	34 3/8	873	19 7/8	505
BES B 029	47 3/8	1203	32 7/8	835	34 3/8	873	30 3/8	772

*Note: Dimensions for indoor models may be smaller by up to 3/8" (10 mm)

NOTE: Discharge hood and legs are optional components

DIMENSIONAL DATA (Models 030 to 075)

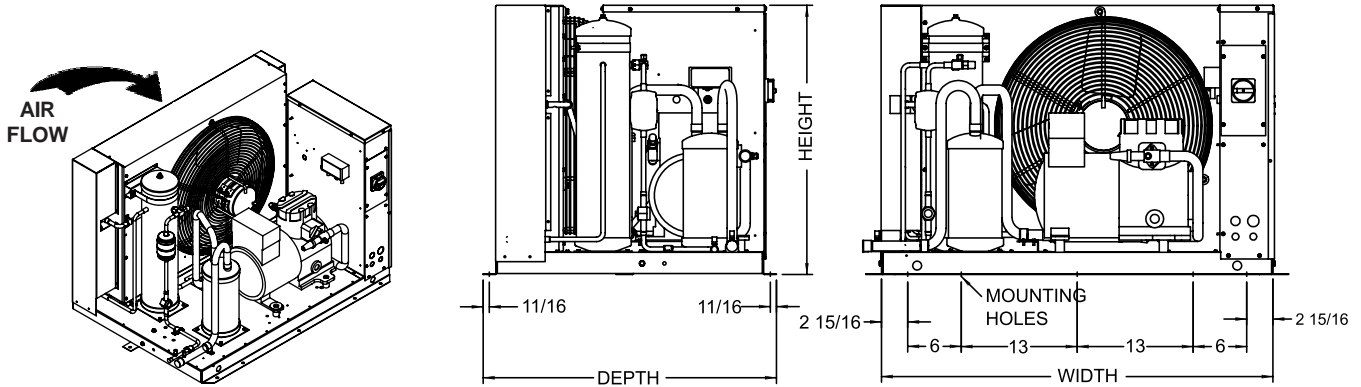

INDOOR DIMENSIONS

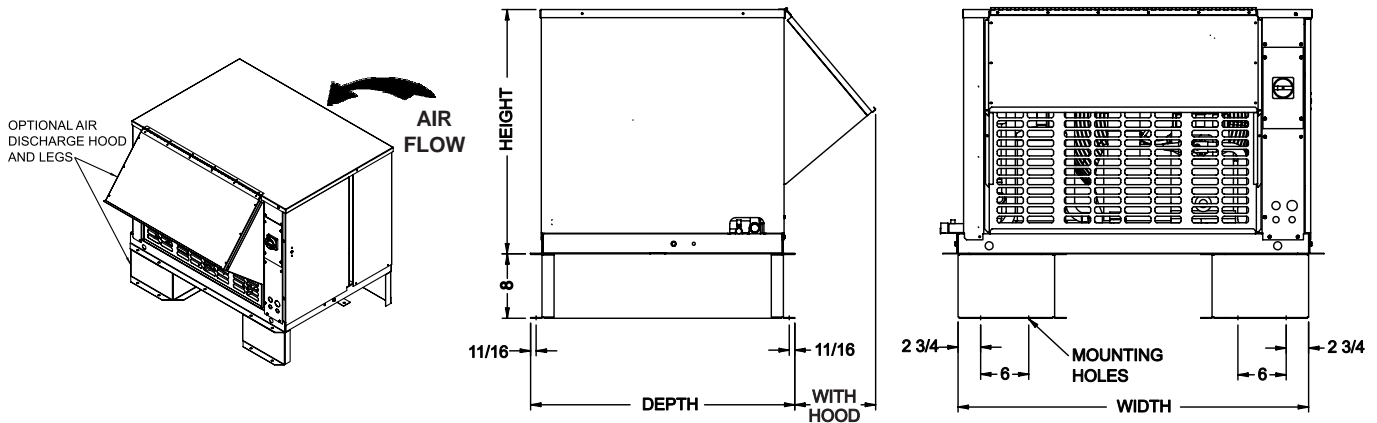

OUTDOOR DIMENSIONS

CONDENSING UNIT MODEL	WIDTH		DEPTH				HEIGHT*	
			Base		With Hood			
	Inches	mm	Inches	mm	Inches	mm	Inches	mm
BES A/B 030	47 3/8	1203	32 7/8	835	43	1092	30 3/8	772
BES B 031	47 3/8	1203	32 7/8	835	43	1092	30 3/8	772
BES A 032	47 3/8	1203	32 7/8	835	43	1092	30 3/8	772
BES A/B 035	47 3/8	1203	32 7/8	835	43	1092	30 3/8	772
BES B 039	47 3/8	1203	32 7/8	835	43	1092	30 3/8	772
BES A/B 040	47 3/8	1203	32 7/8	835	43	1092	30 3/8	772
BES A/B 050	55 5/8	1413	35 7/8	911	43	1092	41 7/8	1064
BES A 051	55 5/8	1413	35 7/8	911	43	1092	41 7/8	1064
BES A/B 060	55 5/8	1413	35 7/8	911	43	1092	41 7/8	1064
BES A 061	55 5/8	1413	35 7/8	911	43	1092	41 7/8	1064
BES A/B 075	55 5/8	1413	35 7/8	911	50	1270	41 7/8	1064
BES A 076	55 5/8	1413	35 7/8	911	50	1270	41 7/8	1064

*Note: Dimensions for indoor models may be smaller by up to 3/8" (10 mm)

NOTE: Discharge hood and legs are optional components



SPECIFICATIONS COPELAND MODELS

CONDENSING UNIT MODEL	COMPRESSOR*	UNIT CONNECTIONS				RECEIVER CAPACITY 90% FULL		SHIPPING WEIGHT			
		SUCTION (OD)		LIQUID (OD)				OUTDOOR		INDOOR	
		Inches	mm	Inches	mm	Lbs.	Kgs	Lbs.	Kgs	Lbs.	Kgs
BESA005H2	HAG-0050	1/2	13	3/8	10	6	2.7	215	98	204	93
BESA008H2	KAN-0075	1/2	13	3/8	10	6	2.7	240	109	230	104
BESA010H2	KAR-0100	5/8	16	3/8	10	6	2.7	270	122	260	118
BESA015H2	KAG-0150	7/8	22	3/8	10	16	7.3	310	141	295	134
BESA020H2	KAKB-0200	7/8	22	1/2	13	16	7.3	320	145	305	138
BESA030H2	ERF1-0310	1 1/8	29	1/2	13	25	11	477	217	432	195
BESA040H2	NRB2-0400	1 1/8	29	1/2	13	25	11	542	246	497	225
BESA050H2	2DC3-0500	1 3/8	35	5/8	16	35	16	766	348	721	326
BESA051H2	2DD3-0500	1 3/8	35	5/8	16	35	16	769	350	724	328
BESA075H2	2DL3-0750	1 3/8	35	5/8	16	35	16	780	355	735	333
BESA076H2	2DA3-0750	1 3/8	35	5/8	16	35	16	780	355	735	333
BESA005M2	HAJ-0050	1/2	13	3/8	10	6	2.7	215	98	205	93
BESA008M2	KAE-0075	5/8	16	3/8	10	6	2.7	240	109	230	104
BESA010M2	KAM-0100	5/8	16	3/8	10	6	2.7	270	122	260	118
BESA021M2	ERC-0200	7/8	22	1/2	13	16	7.3	390	177	370	168
BESA030M2	3RA1-0310	1 1/8	29	1/2	13	25	11	486	221	441	200
BESA050M2	NRM1-0500	1 1/8	29	1/2	13	35	16	738	335	693	314
BESA050H6	2DC3-050E	1 1/8	29	5/8	16	31	14	766	348	721	326
BESA051H6	2DD3-050E	1 1/8	29	5/8	16	31	14	769	350	724	328
BESA075H6	2DL3-075E	1 3/8	35	5/8	16	31	14	780	355	735	333
BESA076H6	2DA3-075E	1 3/8	35	5/8	16	31	14	780	355	735	333
BESA005M6	HAJ-005E	1/2	13	3/8	10	5.2	2.4	215	98	205	93
BESA010M6	KAR-010E	5/8	16	3/8	10	5.2	2.4	270	122	260	118
BESA020M6	KAK-020E	7/8	22	1/2	13	14	6.4	320	145	305	138
BESA021M6	ERC-020E	7/8	22	1/2	13	14	6.3	390	177	370	168
BESA030M6	ERFA-031E	7/8	22	1/2	13	22	10	477	217	432	195
BESA035M6	3RAA-031E	1 1/8	29	5/8	16	22	10	487	221	442	200
BESA040M6	NRB2-040E	1 1/8	29	5/8	16	22	10	542	246	497	225
BESA005L6	KAN-005E	1/2	13	3/8	10	5.2	2.4	240	109	230	104
BESA008L6	KAM-007E	5/8	16	3/8	10	5.2	2.4	270	122	260	118
BESA010L6	KAJ-010E	7/8	22	3/8	10	5.2	2.4	290	132	275	125
BESA015L6	KAL-015E	7/8	22	3/8	10	14	6.4	315	143	300	136
BESA020L6	EAD-021E	7/8	22	3/8	10	14	6.4	385	175	370	168
BESA021L6	EAV-021E	7/8	22	1/2	13	14	6.4	390	177	375	170
BESA030L6	LAHA-032E	1 1/8	29	1/2	13	22	10	493	224	448	203
BESA031L6	NRD1-032E	1 1/8	29	1/2	13	22	10	562	255	517	234
BESA032L6	LACA-032E	1 1/8	29	1/2	13	22	10	491	223	446	202
BESA035L6	2DF3-030E	1 1/8	29	1/2	13	22	10	588	267	543	246
BESA040L6	2DL3-040E	1 1/8	29	1/2	13	22	10	618	281	573	259
BESA060L6	2DB3-060E	1 3/8	35	5/8	16	31	14	781	355	736	333
BESA061L6	3DA3A060E	1 3/8	35	5/8	16	31	14	819	372	774	350
BESA075L6	3DB3A075E	1 3/8	35	5/8	16	31	14	827	376	782	354



SPECIFICATIONS BITZER MODELS

CONDENSING UNIT MODEL	COMPRESSOR*	UNIT CONNECTIONS				RECEIVER CAPACITY 90% FULL		SHIPPING WEIGHT			
		SUCTION (OD)		LIQUID (OD)				OUTDOOR		INDOOR	
		Inches	mm	Inches	mm	Lbs.	Kgs	Lbs.	Kgs	Lbs.	Kgs
BESB029H2	2FC-3.2	1 1/8	29	1/2	13	25	11	386	175	361	163
BESB030H2	2EC-3.2	1 1/8	29	1/2	13	25	11	437	199	392	177
BESB035H2	2DC-3.2	1 1/8	29	1/2	13	25	11	449	204	404	183
BESB040H2	2CC-4.2	1 1/8	29	1/2	13	25	11	452	205	407	184
BESB050H2	4FC-5.2	1 3/8	35	5/8	16	35	16	648	295	603	273
BESB060H2	4EC-6.2	1 3/8	35	5/8	16	35	16	652	296	607	275
BESB075H2	4DC-7.2	1 3/8	35	5/8	16	35	16	655	298	610	276
BESB029H6	2FC-3.2Y	1 1/8	29	5/8	16	22	10	386	175	361	163
BESB030H6	2EC-3.2Y	1 1/8	29	5/8	16	22	10	437	199	392	177
BESB035H6	2DC-3.2Y	1 1/8	29	5/8	16	22	10	449	204	404	183
BESB040H6	2CC-4.2Y	1 1/8	29	5/8	16	22	10	452	205	407	184
BESB050H6	4FC-5.2Y	1 1/8	29	5/8	16	31	14	648	295	603	273
BESB060H6	4EC-6.2Y	1 3/8	35	5/8	16	31	14	652	296	607	275
BESB075H6	4DC-7.2Y	1 3/8	35	5/8	16	31	14	655	298	610	276
BESB030L6	2CC-3.2Y	1 1/8	29	1/2	13	22	10	436	198	391	177
BESB031L6	4FC-3.2Y	1 1/8	29	1/2	13	22	10	463	210	418	189
BESB039L6	4EC-4.2Y	1 1/8	29	1/2	13	22	10	479	218	434	196
BESB050L6	4DC-5.2Y	1 3/8	35	5/8	16	31	14	647	294	602	272
BESB060L6	4CC-6.2Y	1 3/8	35	5/8	16	31	14	658	299	613	277

TYPICAL SYSTEM WIRING DIAGRAM

208-230/1/60

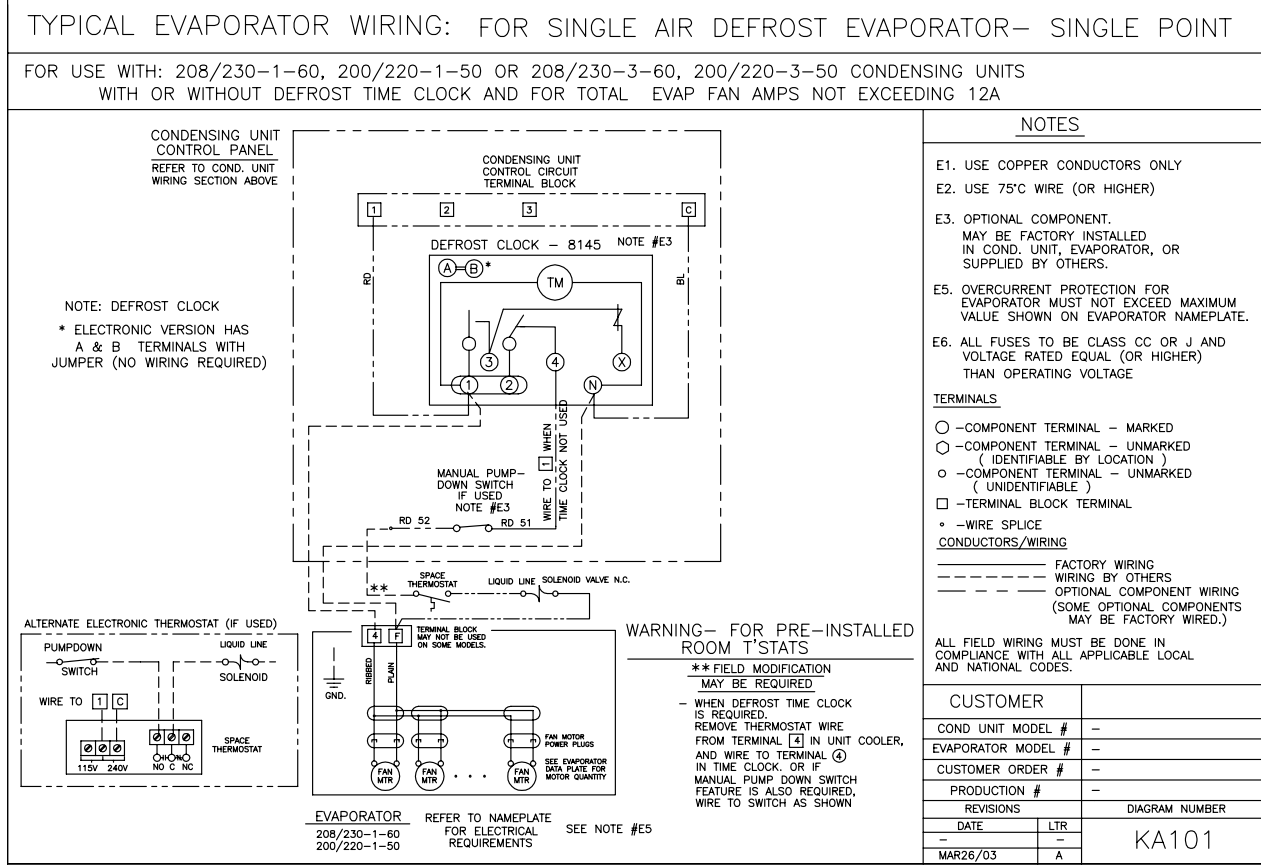
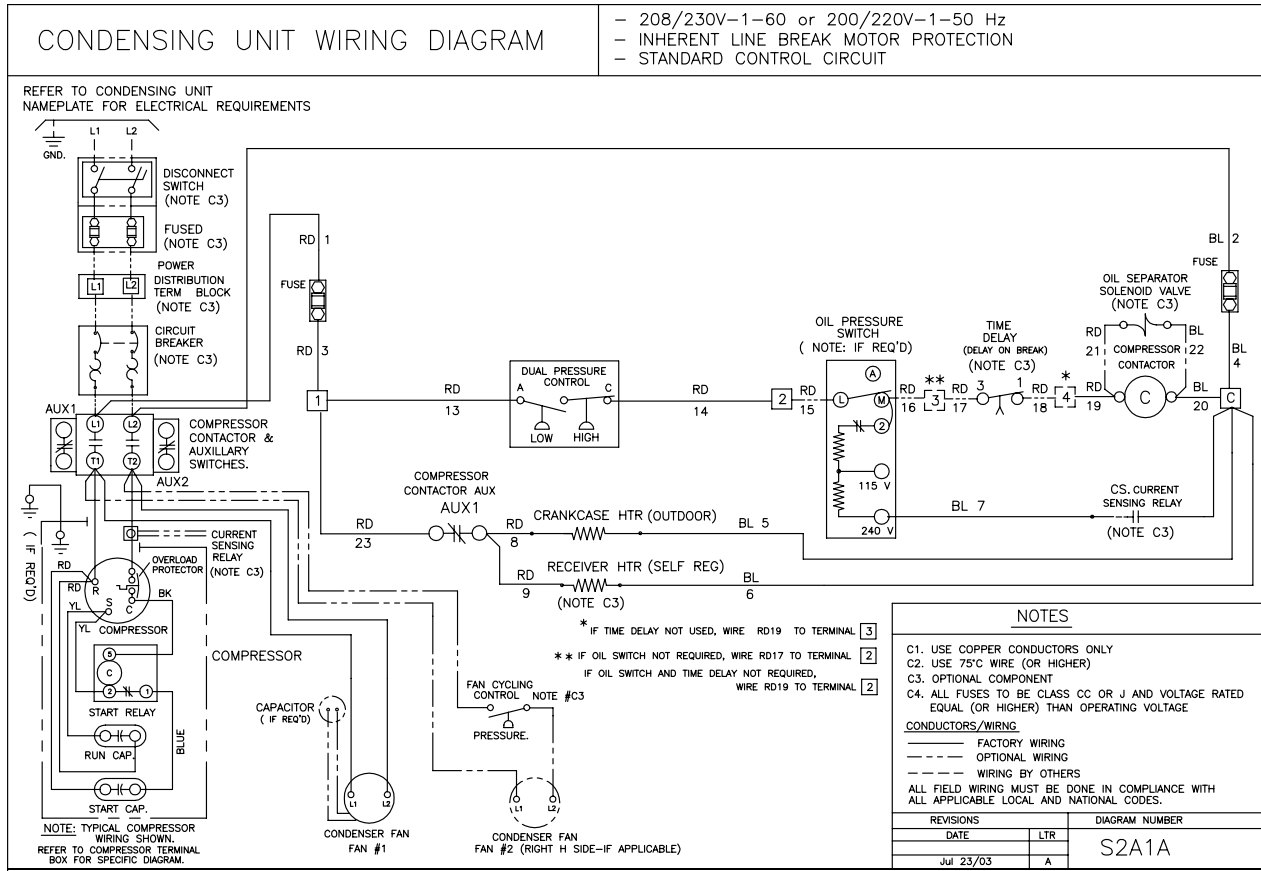

TYPICAL SYSTEM WIRING DIAGRAM

208-230/3/60

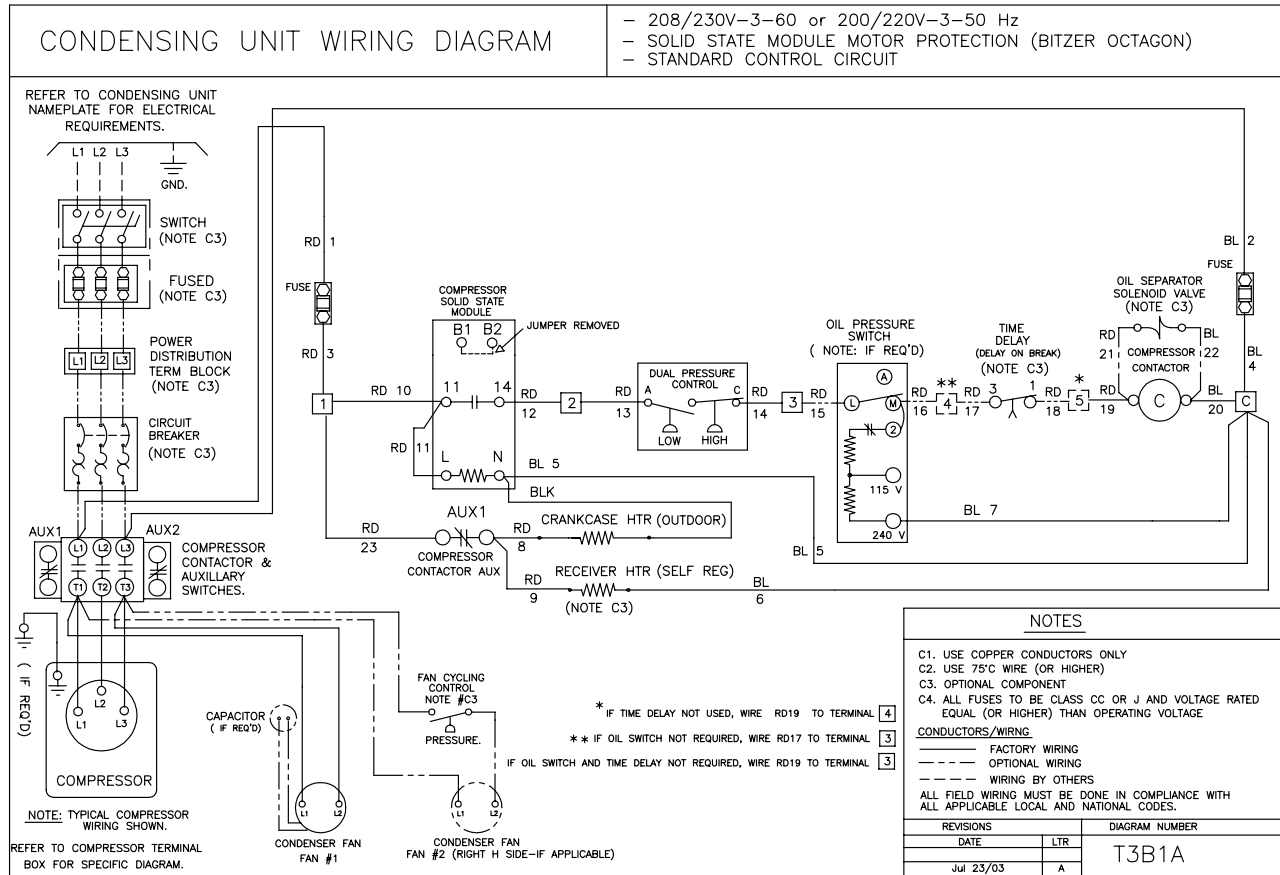

TYPICAL EVAPORATOR WIRING: FOR SINGLE LOW PROFILE ELECT DEFROST EVAPORATOR- SINGLE POINT

FOR USE WITH: 230v SINGLE OR THREE PHASE CONDENSING UNITS WITH DEFROST TIME CLOCK, AND DEFR. HTR. CONTACTOR.

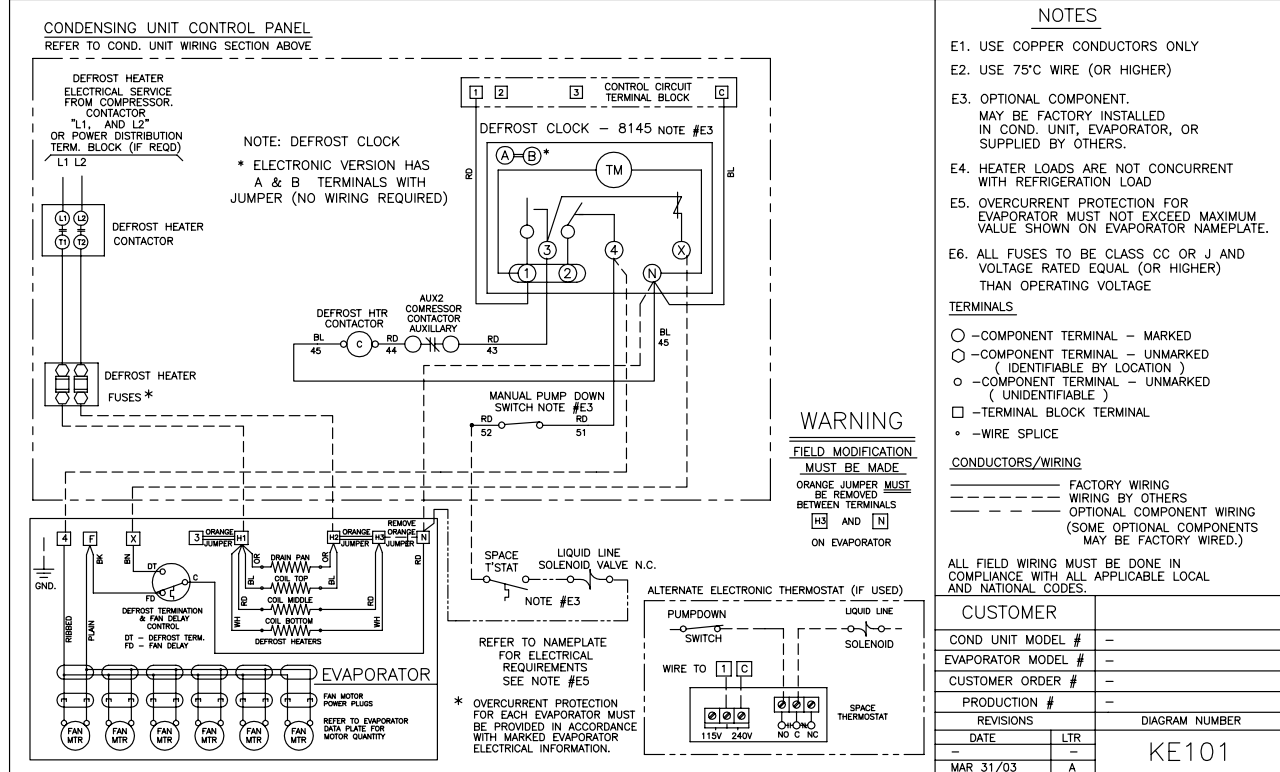

TYPICAL SYSTEM WIRING DIAGRAM

460/3/60, 575/3/60

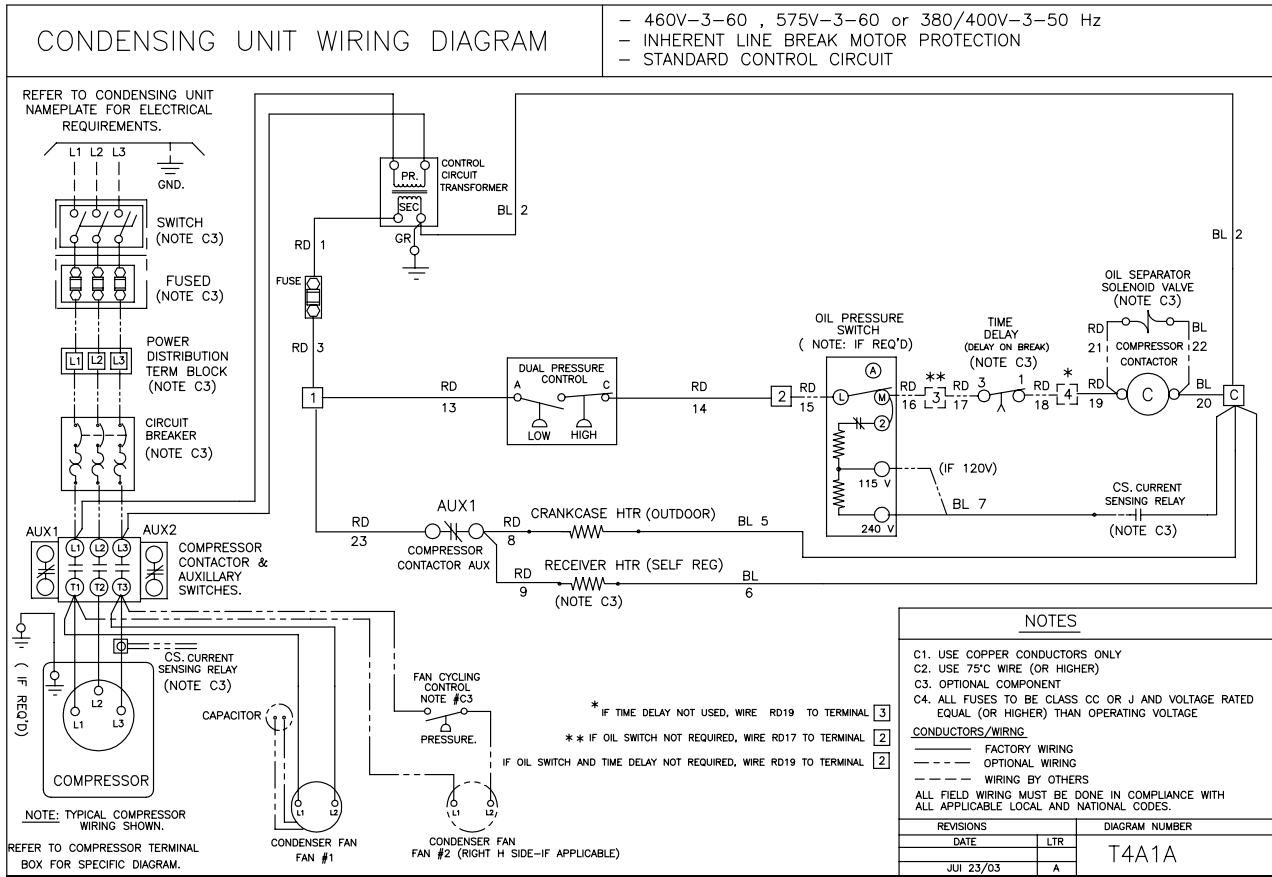

TYPICAL EVAPORATOR WIRING: FOR SINGLE MED PROFILE ELECT DEFROST EVAPORATOR- SINGLE POINT

FOR USE WITH: THREE PHASE CONDENSING UNITS WITH DEFROST TIME CLOCK, & EVAP FAN AND DEF. HTR. CONTACTORS.

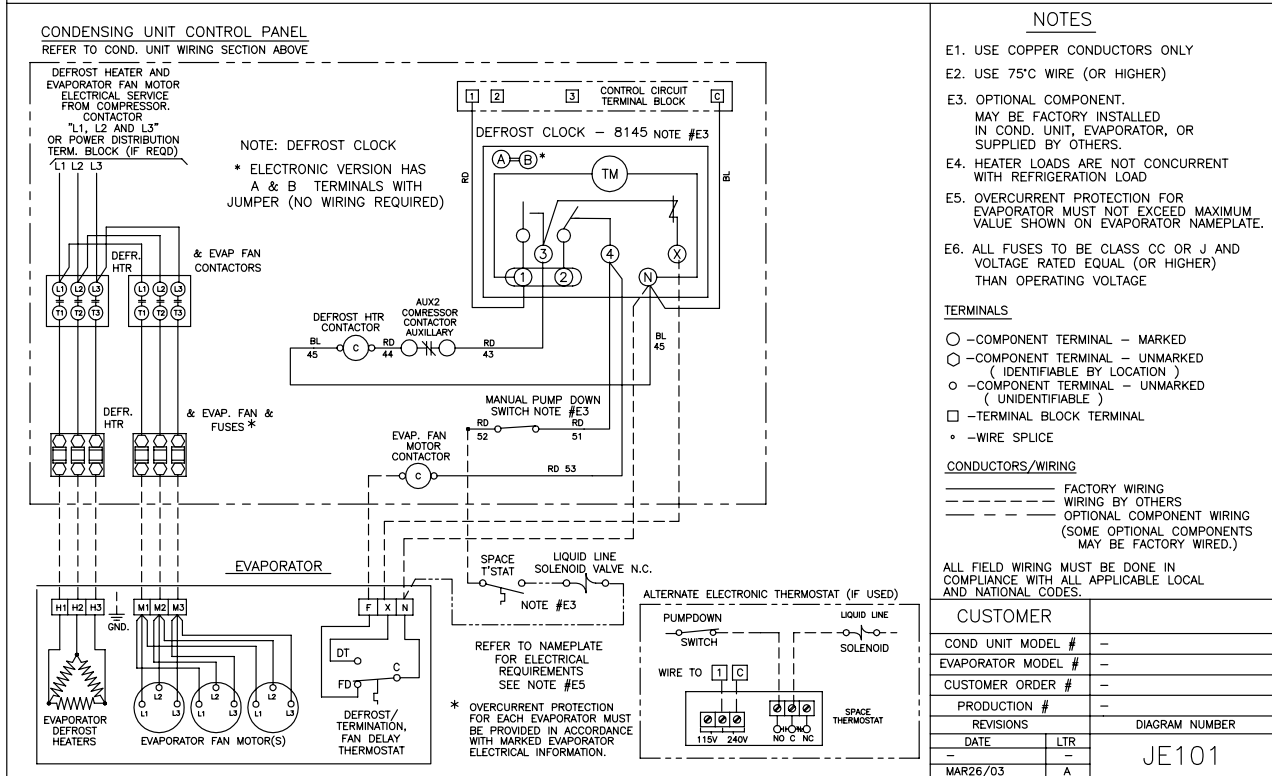

System	
Model Number	Date of Start-Up
Serial Number	Service Contractor
Refrigerant	Phone
Electrical Supply	Fax



General Sales, Parts & Service Manufacturing & Engineering
135 Little Nine Drive, Morehead City, NC 28557
252-240-2829 • 1-800-24-BALLY • FAX: 252-240-0384
e-mail: ballysales@ballyrefboxes.com • www.ballyrefboxes.com

DISTRIBUTED BY:

*Due to Manufacturer's policy of continuous product improvement,
the Manufacturer reserves the right to make changes without notice.*

