

BA/BF Low Profile Unit Coolers

PRODUCT DATA & INSTALLATION

Bulletin: B30-BABF-PDI-16

1047385

Applications:

High, Medium and Low Temperature
-30 °F (-34.5 °C) and Above Room Temperature

Defrost Types:

Air, Electric or Hot Gas Defrost (Reverse Cycle)

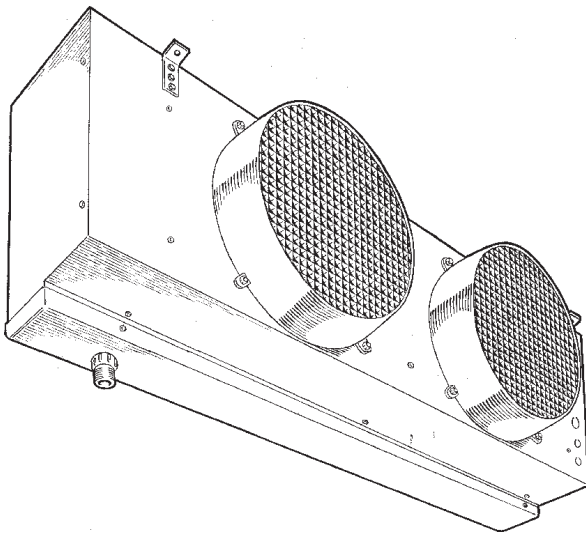

NOMENCLATURE

BA 82 P -HG- S1 A

BALLY LOW PROFILE
UNIT COOLER

BA = MEDIUM TEMPERATURE
APPLICATION

BF = LOW TEMPERATURE
APPLICATION

SIZE
BTUH OF COOLING/100

OPTIONS
P = PRE-ASSEMBLED REMOTE SYSTEM
S = STANDARD UNIT

DEFROST
A = AIR DEFROST
ED = ELECTRIC DEFROST
HG = HOT GAS DEFROST

ELECTRICAL
S1 = 115/1/60
S2 = 208-230/1/60
S6 = 200-220/1/50

REVISION LEVEL
A = 1995 START UP

- Heavy gauge textured aluminum cabinet construction resists scratches/corrosion and minimizes weight for shipment, installation and service.
- Ideal for walk-in coolers/freezers
- Capacity up to 30,600 BTUH nominal.
- Easy access/quick disconnect fan, motor and mount assemblies.
- Reduced operating charge with 3/8" OD tubing
- Spacious end compartment allows for easy component installation.
- Attractive and durable high - density poly propylene fan guards, with built-in throw boosters.
- Terminal board allows for easy electrical connections.
- Refrigerants R22, R404A, R507, R134a, R407A, R407B and R407C.
- Options:
 - High-efficiency PSC motors.
 - Factory mounted solenoid valve, TXV and Thermostat.
 - Fin material and special coatings.
 - Other options available - consult factory.

CONTENTS

	PAGE
Nomenclature	Cover
60Hz Data	2
50Hz Data	3
Dimensional Data	4
Wiring Diagrams	5, 8
TXV Selection Data	9, 11
Nozzle Selection	12
Installation Instructions	13, 15
Service Parts List	16
Service Log	Back
Project Information	Back

60Hz DATA

60Hz

Capacity Data - 60 Hz

Air Defrost Model	BA	41P-A	51P-A	62P-A	82P-A	102P-A	123P-A	153P-A	204P-A	255P-A	306P-A
Capacity-Air Defrost Models	BTUH	4100	5100	6200	8200	10200	12300	15300	20400	25500	30600
	WATTS	1200	1493	1815	2401	2987	3601	4480	5973	7466	8960
Electric Defrost Model	BF	35P-ED	43P-ED	53P-ED	70P-ED	87P-ED	105P-ED	130P-ED	174P-ED	217P-ED	260P-ED
Hot Gas Defrost Model	BF	N/A	N/A	53P-HG	70P-HG	87P-HG	105P-HG	130P-HG	174P-HG	217P-HG	260P-HG
Capacity-Elec. and Hot Gas Defrost Models	BTUH	3500	4300	5300	7000	8700	10500	13000	17300	21700	26000
	WATTS	1025	1259	1552	2050	2547	3074	3806	5065	6354	7613
Air Flow	CFM	800	800	1600	1600	1600	2400	2400	3200	4000	4800
	L/S	378	378	755	755	755	1133	1133	1510	1888	2265
Refrig. Charge **	LB.	1.5	1.9	2.4	2.8	3.8	4.7	5.5	7.5	9.3	11.0
	KG	0.7	0.9	1.1	1.3	1.7	2.1	2.5	3.4	4.2	5.0
Std. Unit Approx. Ship. Weight (w/o refrigerant)	LB.	53	63	89	91	101	118	125	160	208	236
	KG	24	29	40	41	46	54	57	73	94	107

Capacity of air defrost models based on: 10°F T.D., @ +20°F SST (5.5°C T.D., -6.6°C SST)

Capacity of electric and hot gas defrost models based on: 10°F T.D., @ -20°F SST (5.5°C T.D., -28.8°C SST)

* Insert appropriate voltage code: S1 for 115/1/60, S2 for 208-230/1/60. Note: Electric defrost models available only in 208-230/1/60

** R22 at 0 °F SST (-6.6 °C) with coil 30% full.

NOTE:

Defrost heaters can be field converted to operate on 208-230/3/60

Evaporator Capacity Correction Factors for Electric and Hot Gas Defrost Models

Saturated Evaporator Temp.	° F	20	10	0	-10	-20	-30	-40
	° C	-6.7	-12.2	-17.8	-23.3	-28.9	-34.4	-40.0
Correction Factor		1.18	1.15	1.12	1.07	1.00	0.93	0.85

Electrical Data - 60 Hz

Air Defrost and Hot Gas Defrost Models - 115/1/60 and 208-230/1/60

Model	No. of Fans	Electrical Code S1 115/1/60			Electrical Code S2 208-230/1/60		
		FLA @115V	MCA*	MOP	FLA @230V	MCA*	MOP
BA/BF 41,51	1	2.1	2.6	15	1.0	1.3	15
BA/BF 53,62,70, 82,87,102	2	4.2	4.7	15	2.0	2.3	15
BA/BF 105,123,130,153	3	6.3	6.8	15	3.0	3.3	15
BA/BF 174,204	4	8.4	8.9	15	4.0	4.3	15
BA/BF 217,255	5	10.5	11.0	15	5.0	5.3	15
BA/BF 260,306	6	12.6	13.1	15	6.0	6.3	15

FLA = Full Load Amps. MCA = Minimum Circuit Ampacity MOP = Maximum Overcurrent Protection

* Electrical wiring is to be sized in accordance with minimum circuit ampacity

All motors are standard shaded pole type

Electric Defrost Models - 208-230/1/60

Model	Fan Motor Electrical Code S2 208-230/1/60				Defrost Heaters Electrical Code S2 208-230/1/60				Data for defrost heaters - field converted to operate on 208-230/3/60		
	Qty.	FLA @230V	MCA*	MOP	Watts	Heater Amps	MCA*	MOP	Heater Amps	MCA*	MOP
BA/BF 35,43	1	1.0	1.3	15	1080	4.7	5.9	15	3.1	3.9	15
BA/BF 53,70,87	2	2.0	2.3	15	2000	8.7	10.9	15	5.8	7.2	15
BA/BF 105,130	3	3.0	3.3	15	3000	13.0	16.3	20	8.6	10.8	15
BA/BF 174	4	4.0	4.3	15	3840	16.7	20.9	25	11.1	13.8	15
BA/BF 217	5	5.0	5.3	15	4760	20.7	25.9	30	13.7	17.1	20
BA/BF 260	6	6.0	6.3	15	5680	24.7	30.9	35	16.3	20.4	25

FLA = Full Load Amps. MCA = Minimum Circuit Ampacity MOP = Maximum Overcurrent Protection

* Electrical wiring is to be sized in accordance with minimum circuit ampacity

All motors are standard shaded pole type

50 Hz DATA

50Hz

Capacity Data - 50 Hz

High Temp. Model	BA	41P-A	51P-A	62P-A	82P-A	102P-A	123P-A	153P-A	204P-A	255P-A	306P-A
Capacity-Air Defrost	BTUH	3772	4692	5704	7544	9384	11316	14076	18768	23460	28152
Models	WATTS	1104	1374	1670	2209	2748	3313	4121	5495	6869	8243
Electric Defrost Model	BF	35P-ED	43P-ED	53P-ED	70P-ED	87P-ED	105P-ED	130P-ED	174P-ED	217P-ED	260P-ED
Hot Gas Defrost Model	BF	N/A	N/A	53P-HG	70P-HG	87P-HG	105P-HG	130P-HG	174P-HG	217P-HG	260P-HG
Capacity-Elec. and Hot Gas Defrost Models	BTUH	3200	4000	4850	6400	8000	9600	11965	15950	19950	23950
Air Flow	WATTS	937	1171	1420	1874	2342	2811	3503	4670	5841	7013
CFM	CFM	667	667	1333	1333	1333	2000	2000	2667	3333	4000
L/S	L/S	315	315	629	629	629	944	944	1259	1573	1888
Refrig. Charge **	LB.	1.5	1.9	2.4	2.8	3.8	4.7	5.5	7.5	9.3	11.0
	KG	0.7	0.9	1.1	1.3	1.7	2.1	2.5	3.4	4.2	5.0
Std. Unit Approx. Ship. Weight (w/o refrigerant)	LB.	53	63	89	91	101	118	125	160	208	236
	KG	24	29	40	41	46	54	57	73	94	107

Capacity of air defrost models based on: 10°F T.D., @ +20°F SST (5.5°C T.D., -6.6°C SST)
 Capacity of electric and hot gas defrost models based on: 10°F T.D., @ -20°F SST (5.5°C T.D., -28.8°C SST)
 * Insert appropriate voltage code: D for 200-220/1/50. Note: 50Hz models available only in 200-220/1/50
 ** R22 at 0 °F SST (-6.6 °C) with coil 30% full.
NOTE: Defrost heaters can be field converted to operate on 200-220/3/50

Electrical Data - 50 Hz Air Defrost and Hot Gas Defrost Models - 200-220/1/50

Model	No. of Fans	Electrical Code S6 200-220/1/50		
		FLA @200V	MCA*	MOP
BA/BF 41,51	1	0.34	0.43	15
BA/BF 53,62,70,82,87,102	2	0.68	0.77	15
BA/BF 105,123,130,153	3	1.02	1.11	15
BA/BF 174,204	4	1.36	1.45	15
BA/BF 217,255	5	1.70	1.79	15
BA/BF 260,306	6	2.04	2.13	15

FLA = Full Load Amps. MCA = Minimum Circuit Ampacity MOP = Maximum Overcurrent Protection
 * Electrical wiring is to be sized in accordance with minimum circuit ampacity
 All motors are standard shaded pole type

Evaporator Capacity Correction Factors for Electric and Hot Gas Defrost Models

Saturated Evaporator Temp.	° F	20	10	0	-10	-20	-30	-40
	° C	-6.7	-12.2	-17.8	-23.3	-28.9	-34.4	-40.0
Correction Factor		1.18	1.15	1.12	1.07	1.00	0.93	0.85

Electric Defrost Models - 200-220/1/50

Model	Fan Motor Electrical Code S6 200-220/1/50				Defrost Heaters Electrical Code S6 200-220/1/50				Data for defrost heaters - field converted to operate on 200-220/3/50		
	Qty.	FLA @200V	MCA*	MOP	Watts	Heater Amps	MCA*	MOP	Heater Amps	MCA*	MOP
BF 35,43	1	0.34	0.43	15	988	4.5	5.6	15	3.0	3.7	15
BF 53,70,87	2	0.68	0.77	15	1830	8.3	10.4	15	5.5	6.9	15
BF 105,130	3	1.02	1.11	15	2745	12.5	15.6	20	8.3	10.3	15
BF 174	4	1.36	1.45	15	3513	16.0	20.0	25	10.6	13.2	15
BF 217	5	1.70	1.79	15	4355	19.8	24.7	30	13.1	16.4	20
BF 260	6	2.04	2.13	15	5197	23.6	29.5	35	15.6	19.6	25

FLA = Full Load Amps. MCA = Minimum Circuit Ampacity MOP = Maximum Overcurrent Protection
 * Electrical wiring is to be sized in accordance with minimum circuit ampacity
 All motors are standard shaded pole type

Optional High Efficiency PSC Fan Motor Data

Model	No. of Fans	115/1/60			200-220/1/50 and 208-230/1/60		
		FLA	MCA*	MOP	FLA	MCA*	MOP
BA/BF 41,51	1	1.0	1.3	15	0.45	0.56	15
BA/BF 53,62,70,82,87,102	2	2.0	2.3	15	0.90	1.01	15
BA/BF 105,123,130,153	3	3.0	3.3	15	1.35	1.46	15
BA/BF 174,204	4	4.0	4.3	15	1.80	1.91	15
BA/BF 217,255	5	5.0	5.3	15	2.25	2.36	15
BA/BF 260,306	6	6.0	6.3	15	2.70	2.81	15

FLA = Full Load Amps. MCA = Minimum Circuit Ampacity MOP = Maximum Overcurrent Protection
 * Electrical wiring is to be sized in accordance with minimum circuit ampacity

Dimensional Data - Inches (mm)

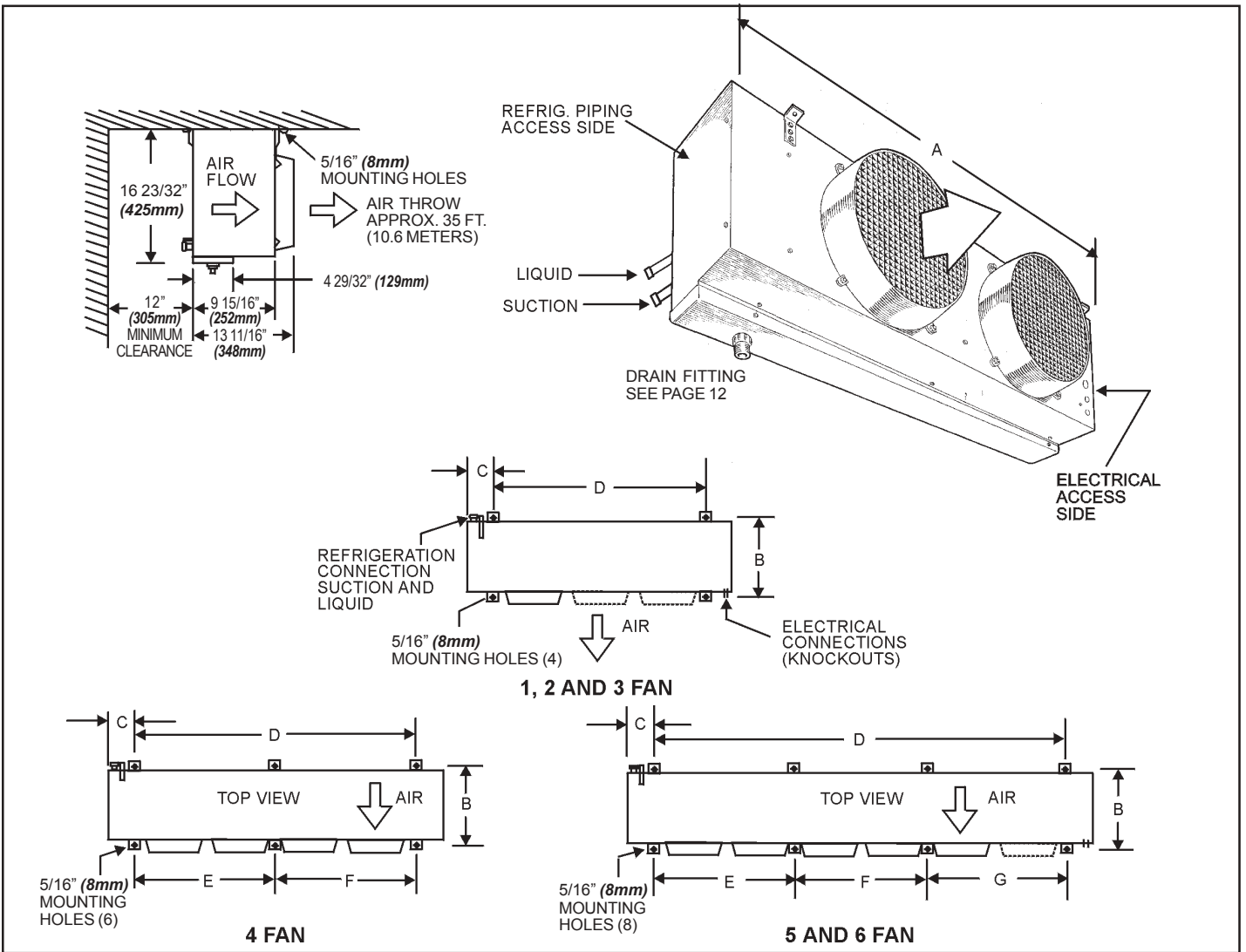

Air Defrost Model	BA	41†	51†	62†	82†	102†	123†	153†	204†	255†	306†	
Electric Defrost Model	BF	35 DED	43 DED	53 DED	70 DED	87 DED	105 DED	130 DED	174 DED	217 DED	260 DED	
Hot Gas Defrost Model	BF	N/A	N/A	53† HG	70† HG	87† HG	105† HG	130† HG	174† HG	217† HG	260† HG	
Liquid Conn. (O.D. Sweat)	In. (mm)	1/2 (12.7)	1/2 (12.7)	1/2 (12.7)	1/2 (12.7)	1/2 (12.7)	1/2 (12.7)	1/2 (12.7)	1/2 (12.7)	1/2 (12.7)	1/2 (12.7)	
Suction Conn. (O.D. Sweat)	In. (mm)	5/8 (15.9)	5/8 (15.9)	5/8 (15.9)	5/8 (15.9)	7/8 (22.2)	7/8 (22.2)	7/8 (22.2)	1 1/8 (28.6)	1 1/8 (28.6)	1 3/8 (34.9)	
Overall Length	A	In. (mm)	28 7/8 (733)	28 7/8 (733)	48 7/8 (1241)	48 7/8 (1241)	48 7/8 (1241)	68 7/8 (1749)	68 7/8 (1749)	88 7/8 (2257)	108 7/8 (2765)	128 7/8 (3273)
Mounting Dimension	B	In. (mm)	11 3/4 (298)	11 3/4 (298)	11 3/4 (298)	11 3/4 (298)	11 3/4 (298)	11 3/4 (298)	11 3/4 (298)	11 3/4 (298)	11 3/4 (298)	
Mounting Dimension	C	In. (mm)	5 1/2 (140)	5 1/2 (140)	5 1/2 (140)	5 1/2 (140)	5 1/2 (140)	5 1/2 (140)	5 1/2 (140)	5 1/2 (140)	5 1/2 (140)	
Mounting Dimension	D	In. (mm)	20 3/4 (527)	20 3/4 (527)	40 3/4 (1035)	40 3/4 (1035)	40 3/4 (1035)	60 3/4 (1543)	60 3/4 (1543)	80 3/4 (2051)	100 3/4 (2559)	120 3/4 (3067)
Mounting Dimension	E	In. (mm)	-	-	-	-	-	-	40 23/32 (1034)	40 23/32 (1034)	40 23/32 (1034)	
Mounting Dimension	F	In. (mm)	-	-	-	-	-	-	40 1/32 (1017)	20 (508)	40 (1016)	
Mounting Dimension	G	In. (mm)	-	-	-	-	-	-	-	40 1/32 (1017)	40 1/32 (1017)	
Approx. Shipping/Net weight	Lbs. (kg)	53/31 (24/14)	63/32 (29/15)	89/48 (40/22)	91/51 (41/23)	101/53 (46/24)	118/74 (54/34)	125/78 (57/35)	160/107 (73/49)	208/135 (94/61)	236/155 (107/70)	

† Insert "S1" for 115/1/60, "S2" for 208-230/1/60 or "S6" for 200-220/1/50 entering service. Electric defrost "S2" is 208-230/1/60 or "S6" for 200-220/1/50.

Wiring Diagrams

Air Defrost

WITHOUT DEFROST TIME CLOCK

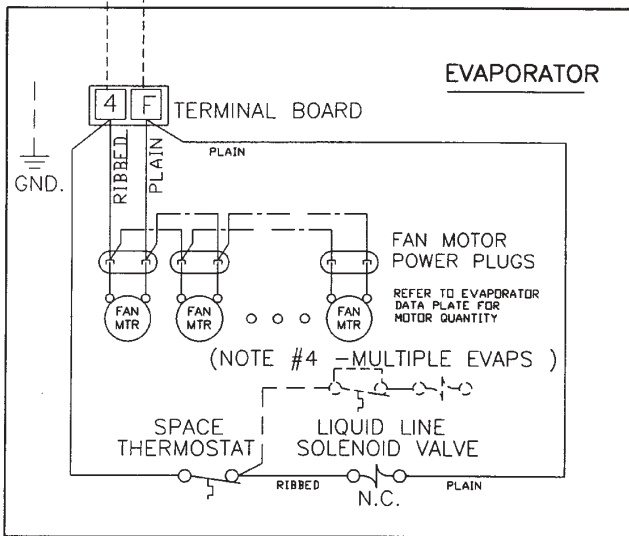
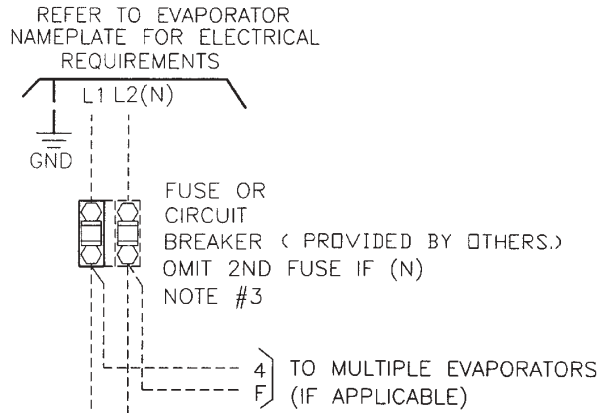

WITH DEFROST TIME CLOCK

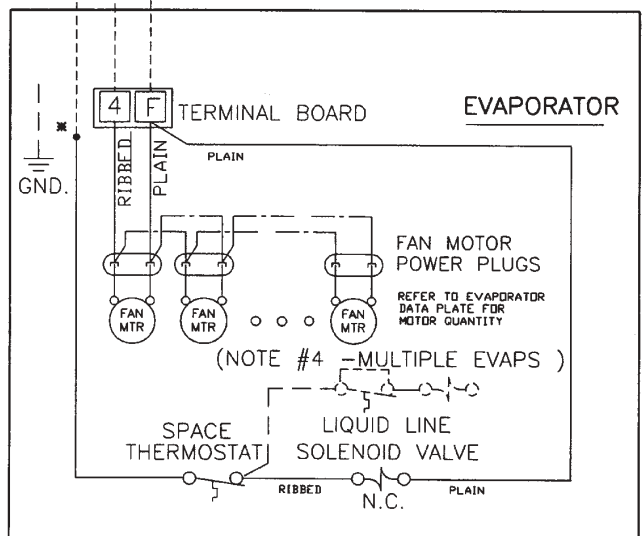
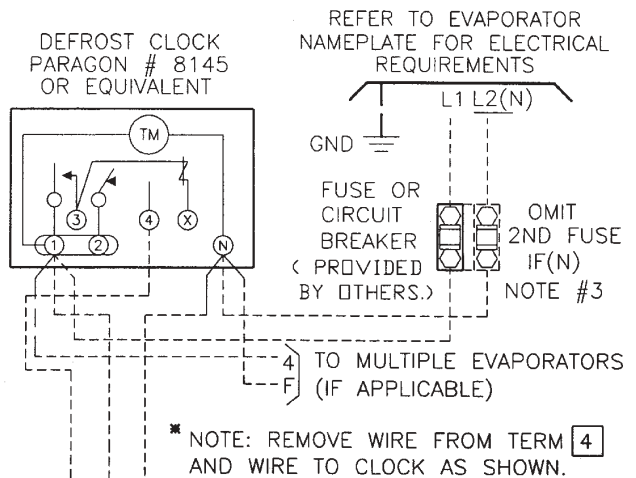

NOTES

- 1). USE COPPER CONDUCTORS ONLY
- 2). USE 75°C WIRE (OR HIGHER)
- 3). OVERCURRENT PROTECTION FOR EVAPORATOR FAN MOTORS AND DEFROST HEATERS MUST NOT EXCEED MAXIMUM VALUE SHOWN ON EVAPORATOR NAMEPLATE.
- 4). ON MULTIPLE EVAPORATORS FIRST T'STAT CONTROLS ALL OTHER SOLENOID VALVES. REMOVE THERMOSTAT WIRE FROM TERMINAL 4 ON SECOND, THIRD ETC. EVAP AND INSTALL JUMPER ACROSS THERMOSTAT (SECOND, THIRD ETC.) AND WIRE TO FIRST EVAP AS SHOWN.

TERMINALS

- -COMPONENT TERMINAL
 - -TERMINAL BLOCK TERMINAL
- ### CONDUCTORS/WIRING

- FACTORY WIRING
- WIRING BY OTHERS

ALL FIELD WIRING MUST BE DONE IN COMPLIANCE WITH ALL APPLICABLE LOCAL AND NATIONAL CODES.

03/28/02 LIT BA AD

Wiring Diagrams

Electric Defrost - Single Evaporator with Defrost Heater Contactor

FOR ALL MODELS USING DEFROST HEATER CONTACTOR

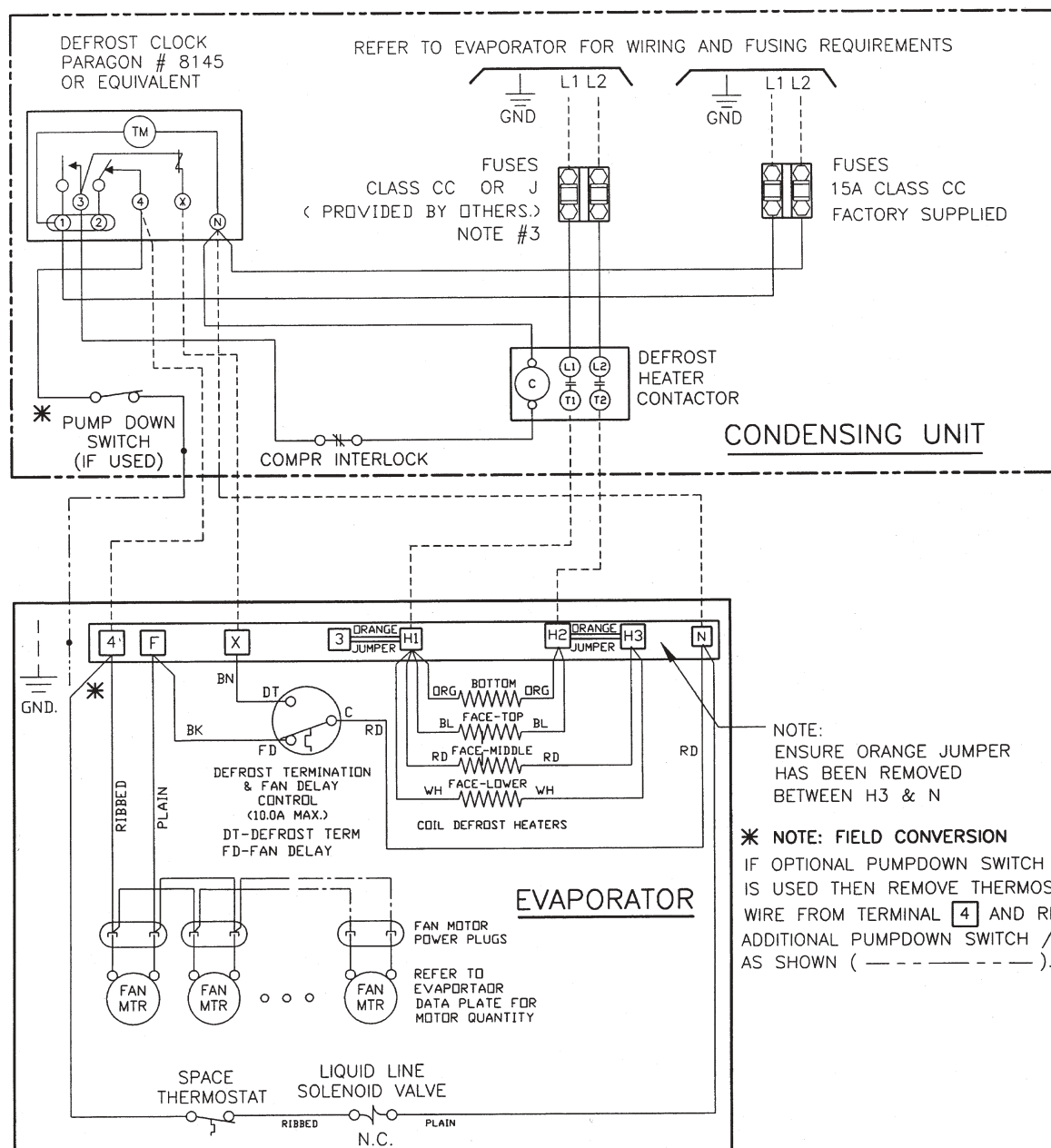

NOTES

1. USE COPPER CONDUCTORS ONLY
2. USE 75°C WIRE (OR HIGHER)
3. OVERCURRENT PROTECTION FOR EVAPORATOR FAN MOTORS AND DEFROST HEATERS MUST NOT EXCEED MAXIMUM VALUE SHOWN ON EVAPORATOR NAMEPLATE.

03/28/02

TERMINALS

- -COMPONENT TERMINAL
- -TERMINAL BLOCK TERMINAL

CONDUCTORS/WIRING

- FACTORY WIRING
- - - - - WIRING BY OTHERS
- OPTIONAL EXTRA WIRING

ALL FIELD WIRING MUST BE DONE IN COMPLIANCE WITH ALL APPLICABLE LOCAL AND NATIONAL CODES. LIT BF ED SINGLE

Wiring Diagrams

Electric Defrost - Multiple Evaporators with Defrost Heater Contactor

FOR ALL MODELS USING DEFROST HEATER CONTACTOR

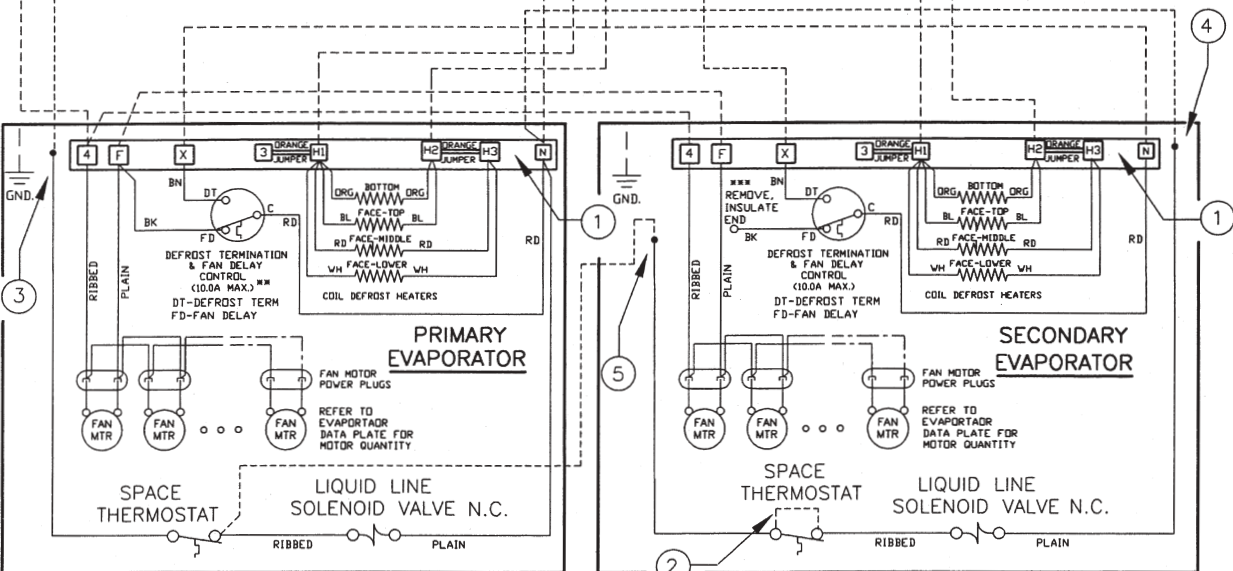
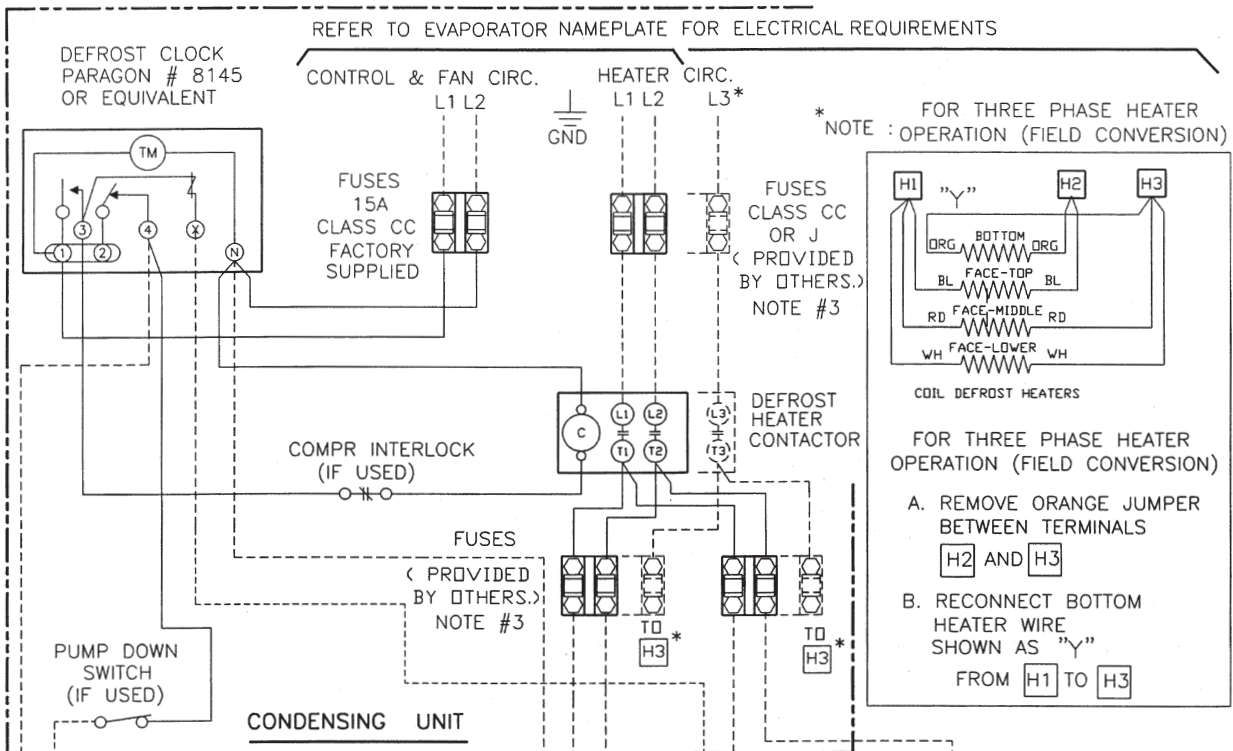

NOTES

- 1). USE COPPER CONDUCTORS ONLY
- 2). USE 75°C WIRE (OR HIGHER)
- 3). OVERCURRENT PROTECTION FOR EVAPORATOR FAN MOTORS AND DEFROST HEATERS MUST NOT EXCEED MAXIMUM VALUE SHOWN ON EVAPORATOR NAMEPLATE.

- ① ENSURE ORANGE JUMPER HAS BEEN REMOVED BETWEEN H3 & N
- ② ADD JUMPER ACROSS SECOND SPACE THERMOSTAT
- ③ IF PUMPDOWN SWITCH IS USED THEN REMOVE WIRE FROM TERMINAL 4 AND REWIRE AS SHOWN
- ④ REMOVE WIRE FROM TERMINAL N AND RE-WIRE AS SHOWN
- ⑤ REMOVE WIRE FROM TERMINAL 4 AND RE-WIRE AS SHOWN

** NOTE: USE FAN CONTACTOR IF TOTAL SYSTEM FAN MOTOR LOAD EXCEEDS 10A.

*** NOTE: ENSURE SECONDARY EVAP FAN DELAY WIRE HAS BEEN REMOVED AND INSULATED.

CONDUCTORS/WIRING

————— FACTORY WIRING
- - - - - WIRING BY OTHERS
ALL FIELD WIRING MUST BE DONE IN COMPLIANCE WITH ALL APPLICABLE LOCAL AND NATIONAL CODES.

03/28/02

LIT BF ED MULTI

Wiring Diagrams

Hot Gas Defrost

ALWAYS REFER TO SYSTEM MANUFACTURER'S WIRING DIAGRAM.

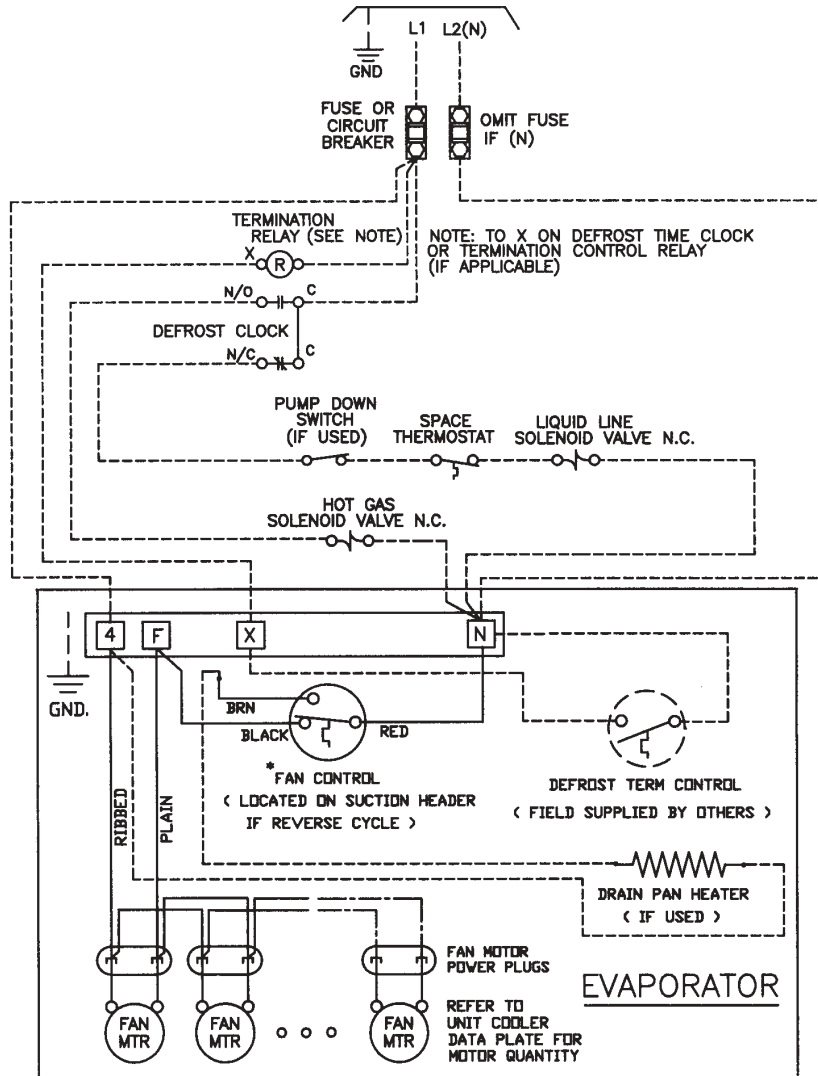

*NOTE: DURING THE HOT GAS DEFROST CYCLE, THE FAN CONTROL DE-ENERGIZES THE FANS AND ENERGIZES THE PAN HEATER (IF APPLIC) ANYTIME TEMPERATURE OF INCOMING REFRIGERANT GAS IS ABOVE 50°F. FANS RE-START WHEN TEMP REACHES 35°F.

NOTES

- 1). USE COPPER CONDUCTORS ONLY
- 2). USE 75°C WIRE (OR HIGHER)
- 3). OVERCURRENT PROTECTION FOR EVAPORATOR FAN MOTORS AND DEFROST HEATERS MUST NOT EXCEED MAXIMUM VALUE SHOWN ON EVAPORATOR NAMEPLATE.

04/01/02

TERMINALS

- -COMPONENT TERMINAL
- -TERMINAL BLOCK TERMINAL

CONDUCTORS/WIRING

- FACTORY WIRING
- - - - - WIRING BY OTHERS
- · - · - · - OPTIONAL FACTORY OR BY OTHERS

ALL FIELD WIRING MUST BE DONE IN COMPLIANCE WITH ALL APPLICABLE LOCAL AND NATIONAL CODES. LIT HG

Thermostatic Expansion Valve Selection

Air Defrost

AIR DEFROST				ALCO VALVE MODEL			SPORLAN VALVE MODEL		
MODEL	T.D. F (C)	CAPACITY		REFRIGERANT			REFRIGERANT		
		BTUH	WATTS	R22	R502/404A/507	R134a	R22	R502/404A/507	R134a
BA 41	10 (5.5)	4,100	1200	HFES-1/4-HC	HFES-1/4-SC	HFES-1/2-MC	EGVE-1/3-VC	EGSE-1/4-SC	EGJE-1/4-JC
	15 (8.3)	6,150	1801	HFES-1/2-HC	HFES-1/2-SC	HFES-3/4-MC	EGVE-1/2-VC	EGSE-1/2-SC	EGJE-1/2-JC
BA 51	10 (5.5)	5,100	1493	HFES-1/2-HC	HFES-1/4-SC	HFES-1-1/2-MC	EGVE-1/2-VC	EGSE-1/2-SC	EGJE-1/2-JC
	15 (8.3)	7,650	2240	HFES-1/2-HC	HFES-1/2-SC	HFES-3/4-MC	EGVE-3/4-VC	EGSE-1/2-SC	EGJE-1/2-JC
BA 62	10 (5.5)	6,200	1815	HFES-1/2-HC	HFES-1/2-SC	HFES-3/4-MC	EGVE-1/2-VC	EGSE-1/2-SC	EGJE-1/2-JC
	15 (8.3)	9,300	2723	HFES-1-HC	HFES-1/2-SC	HFES-3/4-MC	EGVE-3/4-VC	EGSE-1-SC	EGJE-1-JC
BA 82	10 (5.5)	8,200	2401	HFES-1/2-HC	HFES-1/2-SC	HFES-3/4-MC	EGVE-3/4-VC	EGSE-1/2-SC	EGJE-1/2-JC
	15 (8.3)	12,300	3601	HFES-1-HC	HFES-1-SC	HFES-1-MC	EGVE-1-VC	EGSE-1-SC	EGJE-1-JC
BA 102	10 (5.5)	10,200	2987	HFES-1-HC	HFES-1/2-SC	HFES-3/4-MC	EGVE-3/4-VC	EGSE-1-SC	EGJE-1-JC
	15 (8.3)	15,300	4480	HFES-1-1/2-HC	HFES-1/2-SC	HFES-1-MC	EGVE-1-1/2-VC	EGSE-1-SC	EGJE-1-JC
BA 123	10 (5.5)	12,300	3601	HFES-1-HC	HFES-1/2-SC	HFES-1-MC	EGVE-1-VC	EGSE-1-SC	EGJE-1-JC
	15 (8.3)	18,450	5402	HFES-1-1/2-HC	HFES-1-1/4-SC	HFES-1-1/2-MC	EGVE-1-1/2-VC	EGSE-1-1/2-SC	EGJE-1-1/2-JC
BA 153	10 (5.5)	15,300	4480	HFES-1-1/2-HC	HFES-1/2-SC	HFES-1-MC	EGVE-1-1/2-VC	EGSE-1-SC	EGJE-1-JC
	15 (8.3)	22,950	6720	HFES-2-HC	HFES-1-1/2-SC	HFES-1-3/4-MC	EGVE-1-1/2-VC	EGSE-1-SC	EGJE-1-1/2-JC
BA 204	10 (5.5)	20,400	5973	HFES-1-1/2-HC	HFES-1-1/4-SC	HFES-1-1/2-MC	EGVE-1-1/2-VC	EGSE-1-1/2-SC	EGJE-1-1/2-JC
	15 (8.3)	30,600	8960	HFES-2-1/2-HC	HFES-1-SC	HFES-2-1/2-MC	EGVE-3-VC	EGSE-2-SC	EGJE-2-JC
BA 255	10 (5.5)	25,500	7466	HFES-2-HC	HFES-1-1/2-SC	HFES-1-3/4-MC	EGVE-2-VC	EGSE-2-SC	EGJE-1-1/2-JC
	15 (8.3)	38,250	11200	HFES-2-1/2-HC	HFES-3-1/2-SC	HFES-4-MC	EGVE-3-VC	SSE-3-SC	SJE-2-1/2-JC
BA 306	10 (5.5)	30,600	8960	HFES-2-1/2-HC	HFES-1-SC	HFES-2-1/2-MC	EGVE-3-VC	EGVE-2-SC	SJE-2-JC
	15 (8.3)	45,900	13440	HFES-3-HC	HFES-3-1/2-SC	HFES-4-MC	SVE-4-VC	SSE-4-SC	SJE-3-JC

Selections Based on 100°F (37.7 °C) Liquid.

Thermostatic Expansion Valve Selection Electric & Hot Gas Defrost

MODEL	EVAP TEMP		CAPACITY		SPORLAN VALVE MODEL			ALCO VALVE MODEL		
	°F	°C	BTUH	WATTS	R404A/507	R22	R134a	R404A/507	R22	R134a
BF 35	20/25	-6.6/-3.9	4,100	1,200	EGSE-1/4-SC	EGVE-1/3-VC	EGJE-1/4-JC	HFES-1/4-SC	HFES-1/4-HC	HFES-1/2-MC
	10	-12.2	4,018	1,176						
	0	-17.8	3,895	1,140						
	-10	-23.3	3,731	1,092	EGSE-1/4-ZP	EGVE-1/2-ZP40	N/A	HFES-1/4-SZ	HFES-1/2-HZ	N/A
	-20	-28.9	3,485	1,020						
	-30	-34.4	3,239	948						
	-40	-40.0	2,952	864						
BF 43	20/25	-6.6/-3.9	5,100	1,493	EGSE-1/4-SC	EGVE-1/2-VC	EGJE-1/2-JC	HFES-1/4-SC	HFES-1/2-HC	HFES-1/2-MC
	10	-12.2	4,998	1,463						
	0	-17.8	4,845	1,419						
	-10	-23.3	4,641	1,359	EGSE-1/2-ZP	EGVE-3/4-ZP40	N/A	HFES-1/2-SZ	HFES-1/2-HZ	N/A
	-20	-28.9	4,335	1,269						
	-30	-34.4	4,029	1,180						
	-40	-40.0	3,672	1,075						
BF 53	20/25	-6.6/-3.9	6,200	1,815	EGSE-1/2-SC	EGVE-1/2-VC	EGJE-1/2-JC	HFES-1/2-SC	HFES-1/2-HC	HFES-3/4-MC
	10	-12.2	6,076	1,779		EGVE-3/4-VC				
	0	-17.8	5,890	1,725						
	-10	-23.3	5,642	1,652	EGSE-1/2-ZP	EGVE-3/4-ZP40	N/A	HFES-1/2-SZ	HFES-1/2-HZ	N/A
	-20	-28.9	5,270	1,543						
	-30	-34.4	4,898	1,434						
	-40	-40.0	4,464	1,307						
BF 70	20/25	-6.6/-3.9	8,200	2,401	EGSE-1/2-SC	EGVE-3/4-VC	EGJE-1-JC	HFES-1/2-SC	HFES-1/2-HC	HFES-3/4-MC
	10	-12.2	8,036	2,353						
	0	-17.8	7,790	2,281						
	-10	-23.3	7,462	2,185	EGSE-1/2-ZP	EGVE-3/4-ZP40	N/A	HFES-1/2-SZ	HFES-1-HZ	N/A
	-20	-28.9	6,970	2,041						
	-30	-34.4	6,478	1,897						
	-40	-40.0	5,904	1,729						
BF 87	20/25	-6.6/-3.9	10,200	2,987	EGSE-1-SC	EGVE-1-VC	EGJE-1-JC	HFES-1/2-SC	HFES-1-HC	HFES-1-MC
	10	-12.2	9,996	2,927						
	0	-17.8	9,690	2,837						
	-10	-23.3	9,282	2,718	EGSE-1-ZP	EGVE-1-ZP40	N/A	HFES-1-SZ	HFES-1-HZ	N/A
	-20	-28.9	8,670	2,539						
	-30	-34.4	8,058	2,359						
	-40	-40.0	7,344	2,150						
					EGVE-1-1/2-ZP40		HFES-1-1/4-SZ	HFES-1-1/2-HZ		

Selections Based on 100°F (37.7 °C) Liquid.

Thermostatic Expansion Valve Selection

Electric & Hot Gas Defrost

MODEL	EVAP TEMP		CAPACITY		SPORLAN VALVE MODEL			ALCO VALVE MODEL			
	°F	°C	BTUH	WATTS	R404A/507	R22	R134a	R404A/507	R22	R134a	
BF 105	20/25	-6.6/-3.9	12,300	3,601	EGSE-1-SC	EGVE-1-VC	EGJE-1-JC	HFES-1-SC	HFES-1-HC	HFES-1-MC	
	10	-12.2	12,054	3,529							
	0	-17.8	11,685	3,421							
	BF 105	-10	-23.3	11,193	3,277	EGSE-1-ZP	EGVE-1-1/2-ZP40	N/A	HFES-1-SZ	HFES-1-HZ	N/A
		-20	-28.9	10,455	3,061				HFES-1-1/4-SZ	HFES-1-1/2-HZ	
		-30	-34.4	9,717	2,845						
		-40	-40.0	8,856	2,593						
BF 130	20/25	-6.6/-3.9	15,300	4,480	EGSE-1-SC	EGVE-1-1/2-VC	EGJE-1-JC	HFES-1-SC	HFES-1-1/2-HC	HFES-1-1/2-MC	
	10	-12.2	14,994	4,390							
	0	-17.8	14,535	4,256							
	BF 130	-10	-23.3	13,923	4,077	EGSE-1-ZP	EGVE-1-1/2-ZP40	N/A	HFES-1-1/4-SZ	HFES-1-1/2-HZ	N/A
		-20	-28.9	13,005	3,808				HFES-1-1/2-SZ	HFES-2-HZ	
		-30	-34.4	12,087	3,539						
		-40	-40.0	11,016	3,225				EGVE-2-ZP40		
BF 174	20/25	-6.6/-3.9	20,400	5,973	EGSE-1-1/2-SC	EGVE-1-1/2-VC	EGJE-1-1/2-JC	HFES-1-1/4-SC	HFES-1-1/2-HC	HFES-1-3/4-MC	
	10	-12.2	19,992	5,854							
	0	-17.8	19,380	5,674							
	BF 174	-10	-23.3	18,564	5,436	EGSE-1-1/2-ZP	EGVE-2-ZP40	N/A	HFES-1-1/2-SZ	HFES-2-HZ	N/A
		-20	-28.9	17,340	5,077				HFES-2-SZ	HFES-2-1/2-HZ	
		-30	-34.4	16,116	4,719						
		-40	-40.0	14,688	4,301				EGSE-2-ZP		
BF 217	20/25	-6.6/-3.9	25,500	7,466	EGSE-2-SC	EGVE-2-VC	EGJE-2-JC	HFES-1-1/2-SC	HFES-2-HC	HFES-1-3/4-MC	
	10	-12.2	24,990	7,317			EGJE-1-1/2-C			HFES-2-1/2-MC	
	0	-17.8	24,225	7,093							
	BF 217	-10	-23.3	23,205	6,794	EGSE-2-ZP	EGVE-2-ZP40	N/A	HFES-2-SZ	HFES-2-1/2-HZ	N/A
		-20	-28.9	21,675	6,346		EGVE-3-ZP40		HFES-3-1/2-SZ		
		-30	-34.4	20,145	5,898						
		-40	-40.0	18,360	5,376		SVE-3-ZP40				
BF 260	20/25	-6.6/-3.9	30,600	8,960	SSE-3-SC	EGVE-3-VC	SJE-2-JC	HFES-2-SC	HFES-2-HC	HFES-2-1/2-MC	
	10	-12.2	29,988	8,780							
	0	-17.8	29,070	8,512							
	BF 260	-10	-23.3	27,846	8,153	SSE-3-ZP	SVE-3-ZP40	N/A	HFES-2-SZ	HFES-2-1/2-HZ	N/A
		-20	-28.9	26,010	7,616		SVE-4-ZP40		HFES-3-1/2-SZ	HFES-3-HZ	
		-30	-34.4	24,174	7,078						
		-40	-40.0	22,032	6,451						

Selections Based on 100°F (37.7 °C) Liquid.

Electrical View

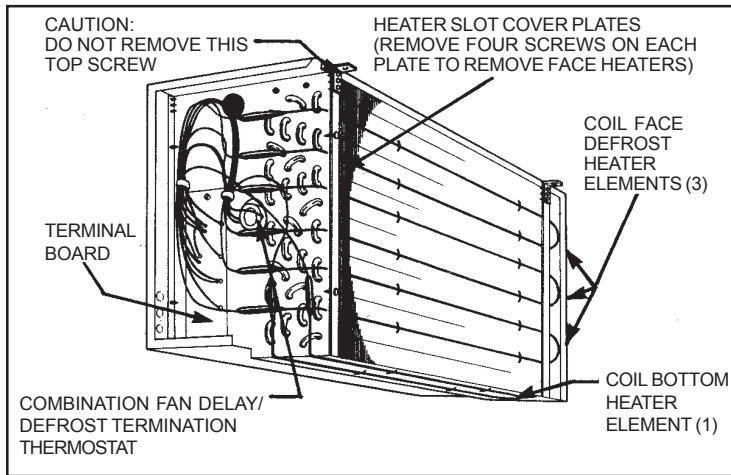

Piping View

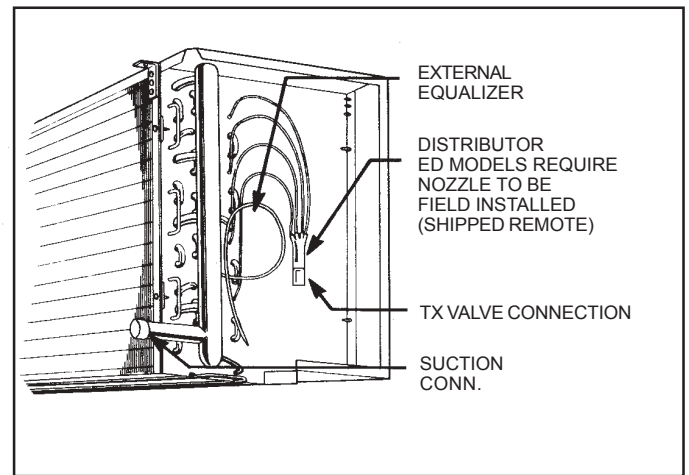

Hot Gas (Reverse Cycle Only)

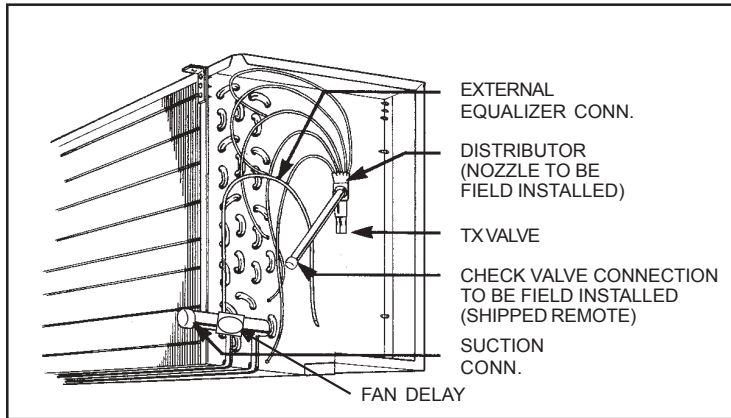

Drain Pan

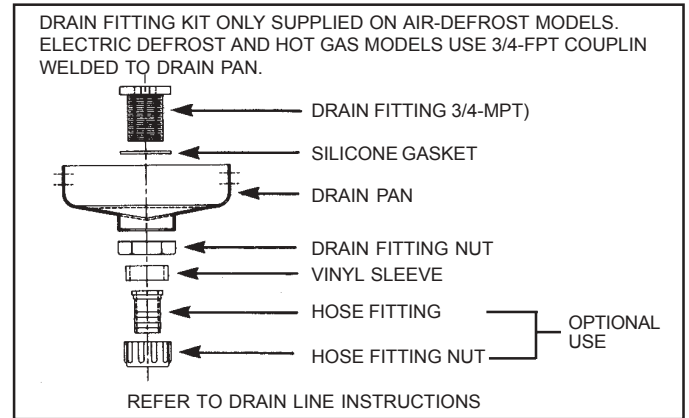

Nozzle Selection

STANDARD NOZZLES FACTORY INSTALLED FOR ALL AIR DEFROST MODELS	
MODEL NUMBER	NOZZLE (Factory Installed)
BA41A	L-1/2
BA51A	L-3/4
BA62A	L-3/4
BA82A	L-1
BA102A	L-1 1/2
BA123A	L-1 1/2
BA153A	L-2
BA204A	L-3
BA255A	E-4
BA306A	E-4

Standard Nozzle for all refrigerants. Based on 25°F (-3.8 °C) S.S.T. @ 10°F (5.5 °C) TD.

* STANDARD NOZZLES SUPPLIED LOOSE BY THE FACTORY				
T.D. °F (°C)	8 to 12 (4.4 to -6.6)			
**Temp. °F Range °C	30 to -20 (-1.1 to -28.9)	-10 to -30 (-23.3 to -34.4)	20 to -15 (-6.7 to -26.1)	
REFRIGERANT				
MODEL No.	R-12, R134a	R-502, R-404a, R-507	R-22	
BF35 ED	L - 3/4	L - 1	L - 1/2	
BF43 ED				
BF53 ED	L - 1	L - 1-1/2	L - 3/4	
BF53 HG	J - 1	J - 1-1/2	J - 3/4	
BF70 ED	L - 1-1/2	L - 2	L - 3/4	
BF70 HG	J - 1-1/2	J - 2	J - 3/4	
BF87 ED	L - 2	L - 2-1/2	L - 1	
BF87 HG	J - 2	J - 2-1/2	J - 1	
BF105 ED	L - 2	L - 3	L - 1-1/2	
BF105 HG	J - 2	J - 3	J - 1-1/2	
BF130 ED	L - 3	L - 4	L - 1-1/2	
BF130 HG	G - 3	G - 4	G - 1-1/2	
BF174 ED	L - 4	L - 6	L - 2	
BF174 HG	G - 4	G - 5	G - 2	
BF217 ED	E - 5	E - 8	E - 3	
BF217 HG				
BF260 ED	E - 6	E - 8	E - 3	
BF260 HG				

* 3 Nozzles one for each refrigerant type are included in a cloth bag supplied only with Electric and Hot Gas Defrost models.

ALTERNATE NON-STANDARD NOZZLE SELECTIONS			
T.D. °F (°C)	8 to 12 (4.4 to 6.6)		
**Temp. °F Range °C	20 to -40 (-6.7 to -40)	-30 to -40 (-34.4 to -40)	-16 to -40 (-26.7 to -40)
REFRIGERANT			
MODEL No.	R-12, R134a	R-502, R-404A, R-507	R-22
BF35 ED	L - 1	L - 1	L - 3/4
BF43 ED	L - 1-1/2	L - 1-1/2	L - 3/4
BF53 ED	L - 1-1/2	L - 1-1/2	L - 1
BF53 HG	J - 1-1/2	J - 1-1/2	J - 1
BF70 ED	L - 2	L - 2-1/2	L - 1-1/2
BF70 HG	J - 2	J - 2-1/2	J - 1-1/2
BF87 ED	L - 3	L - 4	L - 1-1/2
BF87 HG	J - 3	J - 4	J - 1-1/2
BF105 ED	L - 3	L - 4	L - 2
BF105 HG	J - 3	J - 4	J - 2
BF130 ED	L - 4	L - 5	L - 2
BF130 HG	G - 4	G - 5	G - 2
BF174 ED	L - 5	L - 8	L - 3/4
BF174 HG	G - 5	G - 8	G - 3
BF217 ED	E - 6	E - 8	E - 3
BF217 HG			
BF260 ED	E - 8	E - 10	E - 4
BF260 HG			

** S.S.T.

If correct nozzle is not available, the proper orifice size can be drilled in the field using the following chart

NOZZLE ORIFICE No.	DRILL SIZE IN.
1/2	.070
3/4	.086
1	.0995
1-1/2	.120
2	.1406
2-1/2	.157
3	.172
4	.199
5	.211
6	.242
8	.266
10	.281

Installation Instructions

INSTALLATION

The installation and start-up of Unit Coolers should only be performed by qualified refrigeration mechanics. This equipment should be installed in accordance with all applicable codes, ordinances and local by-laws.

INSPECTION

Inspect all equipment before unpacking for visible signs of damage or loss. Check shipping list against material received to ensure shipment is complete.

IMPORTANT: Remember, you, the consignee, must make any claim necessary against the transportation company. Shipping damage or missing parts, when discovered at the outset, will prevent later unnecessary and costly delays.

If damage or loss during transport is evident, make claim to carrier, as this will be their responsibility, not the manufacturer's.

Should carton be damaged, but damage to equipment is not obvious, a claim should be filed for "concealed damage" with the carrier.

IMPORTANT: The electrical characteristics of the unit should be checked at this time to make sure they correspond to those ordered and to electrical power available at the job site.

Save all shipping papers, tags and instruction sheets for reference by installer and owner.

APPLICATION

BA/BF Unit Coolers are designed for use with refrigerants as listed in page 1. At room temperatures above 34°F (1.1°C) (and evaporating temps no lower than 24°F (-4.4°C)) positive coil defrosting (Electric or Hot Gas) is not required. (The air flowing through the coil will accomplish the defrost). At room temperatures of 34°F (1.1°C) and below, positive defrosting is required (either Electric (ED) or Hot Gas (HG) in model nomenclature). These models require the use of (1) Time Clock or equivalent (to initiate and terminate the defrost cycle), and (2) Defrost Termination Control (to prevent unnecessary prolonged heating and steaming of the coil once all the ice and frost has melted).

The coil must not be exposed to any abnormal atmospheric or acidic environments. This may result in corrosion to the cabinet and possible coil failure (leaks). (Consult manufacturer for optional baked on phenolic protective coatings).

LOCATION

The unit location in the room should be selected to ensure uniform air distribution throughout the entire space to be refrigerated. Be sure that the unit does not draw air in, or blow directly out, through an opened door and that the product does not obstruct the free circulation of air. Allow a minimum of 24" clearance at each end. BA/BF Low Profile Unit Coolers draw air through the coil and discharge air from fans. Consideration should be given to the coil location in order to minimize the piping run length to the condensing unit and floor drain.

EXPANSION VALVE (TXV) SELECTION

All units require the use of an **externally equalized** expansion valve. (A 1/4" (6 mm) O.D. equalizer line has been provided on the coil) TX valves should **not** be selected strictly by their nominal ton rating. (This rating is based at a specific pressure differential and entering liquid temperature). Since applications will differ it is suggested the following selection procedure be followed.

1. Determine actual unit cooler BTUH or KW (thermal). The nominal rating is based at 10 °F T.D. (5.5°C) (Room Temp. minus Evap. Temp.). Note that a higher / lower operating T.D. will increase / decrease this capacity rating by their direct ratio.
2. Determine the pressure drop across the valve by subtracting the suction (evaporating) pressure from the high side liquid pressure. Note: Also subtract the distributor pressure loss (use approx. 25 psig (1.1 bar) for R134a and 35 psig (2.4 bar) for R22, R404A, R507, R407A, R407B and R407C.
3. Estimate entering liquid temperature. Temperatures lower than 100 °F (37.7 °C) increase valve capacity ratings. Refer to valve manufacturer's specs for details.
4. Select valve from the valve manufacturer selection charts for the appropriate refrigerant, evaporating temp and pressure drop.
5. Ensure appropriate nozzle has been installed in the distributor before installing valve. After following the manufacturer's installation instructions and after the room has reached the desired temperature the valve superheat should be checked. This will confirm that the evaporator is operating properly and performing to maximum efficiency. The superheat should be around 5 (2.7 °C) to 8 °F (4.4 °C) for a 10 to 12 °F T.D. (5.5 to 6.6 °C). Too high or low a super heat will result in unsatisfactory system performance and possible compressor problems.

Installation Instructions (cont'd)

NOZZLE INSTALLATION

All Air Defrost unit cooler models (**not** ED or HG) have the nozzles factory installed in the liquid distributor. All ED (Electric Defrost) and HG (Hot Gas Defrost) models require the nozzles to be field installed. Three sizes are packaged in a bag and are placed in the distributor end compartment. For correct selection (based on applicable refrigerant and temperature application) refer to the nozzle selection table on P. 12. The nozzle retainer clip (in distributor) must be removed before inserting nozzle. Re-install clip ensuring nozzle is properly in place.

MOUNTING

Refer to dimensional drawing for recommended mounting arrangements. Formed mounting channels are provided for flush mounting to the ceiling. Ensure adequate clearance is provided behind the coil as well as each end (to enable access to the electrical and refig. compartments).

Ensure that the ceiling is level since the drain pan has been sloped for drainage during the defrost cycle.

DRAIN LINE

The drain line should be run from the drain connection, sloping at least 1/4" (**6 mm**) per foot. A trap in a warm area outside the room will allow proper draining through the tubing. Connection should be made to proper drainage facilities that comply with local regulations.

To prevent freeze-up when the temperature of the refrigerated space is 35 °F (**1.7 °C**) or lower, the drain line should be heated along its run inside the cold room. The heated drain line should be insulated. It is recommended that the heater be energized at all times. A heat input of 20 watts per foot in a 28°F (**-2.2°C**) room, is satisfactory. Drain line heaters are not required for constant room temperature above 35°F (**1.6°C**).

The drain pan may be mounted with the drain fitting at either end (remove and relocate pan). See page 17 for drain fitting details.

Ensure that the drain line has sufficient slope for proper drainage (prevention of ice build up/blockage in pan).

PIPING

Refrigerant line sizes are important and **may not** be the same size as the coil connections. Consult "Recommended refrigerant line sizes" charts in any standard reference book for proper line sizing.

Refrigerant piping and control system should be designed to prevent possible liquid slugging (from oil or refrigerant) of the compressors on start-up after the defrost cycle. On Hot Gas Defrost Systems the suction accumulator should be at least 2.5 times the coils operating charge.

See Dimensional data for line locations. For Reverse Cycle Hot Gas models see sketch below for typical unit piping. These models include a check valve (unmounted) packaged along with the nozzle in the refig. connection compartment end panel.

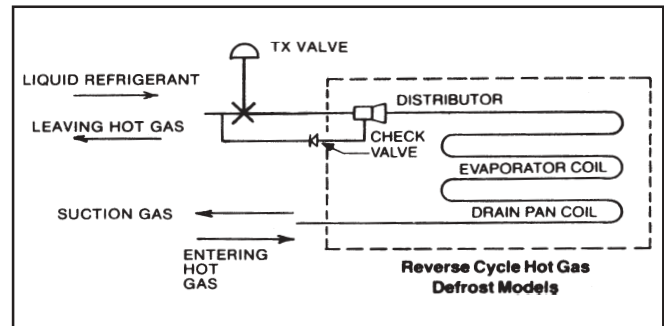

WIRING

Wire system in accordance with governing standards and local codes. See data and wiring diagrams on pages 5 to 8 for wiring arrangement. Electrical wiring is to be sized in accordance with minimum circuit ampacity rating (MCA).

For ease of identifying the proper wiring terminal, unit wiring is color coded and terminal block connections are identified.

When **fan delay thermostats** (combination fan delay and defrost termination) are installed, on start-up, the fans do not operate until the coil temperature is reduced to approximately 26 °F (**-3.3°C**). It is normal for the fans to cycle a few times until the room temperature is brought down. At higher evaporating temperatures this control may not close and therefore should either be by-passed or replaced with an adjustable type. (set for a higher temperature cut-in point).

Installation Instructions (cont'd)

SYSTEM CHECK

Before Start-Up:

1. All wiring should be in accordance with local codes.
2. Refrigerant lines should be properly sized.
3. Off cycle defrost and electric defrost systems preferably must include a liquid line solenoid valve and suction accumulator.
4. Thorough evacuation and, dehydration has been performed.
5. The suction, discharge, and receiver service valves must be open.
6. The system preferably must include a liquid line drier moisture indicator and suction filter.
7. Pour enough water into the drain pan to allow a good check on drainage and seal the trap.

After Start-Up:

1. Check the oil level to be sure the oil charge is correct.
2. On initial start up the fans do not start until coil temperature is pulled down to approximately 35 °F (1.7 °C) on the hot gas coil. Also, it is normal for the fans to cycle a few times until the room temperature is pulled down.
3. If necessary, temporarily by-pass fan delay control (to run fans until room temp is lowered).
4. Be sure that the expansion valve is properly set to provide the correct amount of superheat.
5. In general, evaporators running with a TD of 10 °F should have a superheat reading of 5° to 8 °F (2.7 °C to 4.4 °C). For evaporators with a higher TD, the superheat should be 8° to 12°F (4.4 °C to 6.6 °C).
6. Heavy moisture loads are usually encountered when starting the system for the first time. This will cause a rapid build-up of frost on the unit cooler. During the initial pull down, we suggest that the frost build-up be watched and defrosted manually as required. This may be done by rotating the inner dial on the timer until the pin in the outer dial is directly opposite the timer pointer. (Paragon 8145-20 Timer by others).
7. Observe that the system goes through at least one complete DEFROST CYCLE.

MAINTENANCE

The unit should be periodically inspected for any dirt or build-up on the fin surface and cleaned if necessary with a soft whisk or brush. Also ensure coils inner and outer drain pans do not have any ice build-up from improper defrost operation. When replacing heater elements first remove heater retainer brackets and heater clips.

Service Parts List

DESCRIPTION	PART NUMBER	
FAN MOTOR 115V	1043336	
FAN MOTOR 208-230V	1043766	
MOTOR MOUNT	1043304	
FAN BLADE	1043667	
MOLDED FAN GUARD/WIRE FAN GUARD	1043305/1046145	
* FAN DELAY / DEFROST TERM. CONTROL	1072338	
DRAIN FITTING KIT	1043544-001	
DEFROST HEATERS (ELECTRIC DEFROST MODELS ONLY):	COIL FACE	COIL BOTTOM
MODEL	HEATERS (3 REQ'D)	HEATER (1 REQ'D)
BF 35/43 DED	270W 501321-001	500W 1043603-001
BF 53/70/87 DED	500W 501321-002	900W 1043603-002
BF 105/130 DED	750W 501321-003	1300W 1043603-003
BF 174 DED	960W 501321-004	1700W 1043603-004
BF 217 DED	1190W 501321-005	2100W 1043603-005
BF 260 DED	1420W 501321-006	2500W 1043603-006
HEATER RETAINER (WIRE CLIP)	505377	
TERMINAL BOARDS:		
HIGH TEMP (AIR DEFROST) MODELS	1043529	
ELECTRIC DEFROST MODELS	1043538	
HOT GAS DEFROST MODELS	1043543	

* NOT USED ON HIGH TEMP (AIR DEFROST) MODELS

Service Parts List

**Service Parts List
Label
To Be Attached
HERE**

SERVICE LOG

DATE	COMMENTS

Project Information

System	
Model Number	Date of Start-Up
Serial Number	Service Contractor
Refrigerant	Phone
Electrical Supply	Fax



General Sales, Parts & Service Manufacturing & Engineering
135 Little Nine Drive, Morehead City, NC 28557
252-240-2829 • 1-800-24-BALLY • FAX: 252-240-0384
e-mail: ballysales@ballyrefboxes.com • www.ballyrefboxes.com

DISTRIBUTED BY: _____

