

Instructions:

1. Disconnect the power supply to the vapor-proof light junction box on the interior of the door panel.
2. Disconnect the crossover cord from the vapor-proof light junction box. Allow the cord to hang free from the door cap.
3. Unscrew hinge screws from door panel and carefully remove door cap.
4. Lay door cap on work surface with the door cap interior facing up.
5. Drill out $\frac{1}{8}$ " rivets that mount dual gasket assembly using a $\frac{9}{64}$ " drill. Remove dual gasket assembly.
6. Install new $\frac{1}{8}$ " rivets into existing holes.
7. Inspect and clear plastic extrusion ridge that runs along the inside of door offset.
8. After centering new gasket along bottom of door cap, drive gasket stem into ridge using wood block and hammer with light taps.
9. Reinstall door and connect power.
10. New gasket should slightly drag on step plate or floor surface. Gasket may need to be trimmed if it drags excessively and inhibits door closure.

For doors manufactured before 1980 see other side.

NEW GASKET INSTALLATION

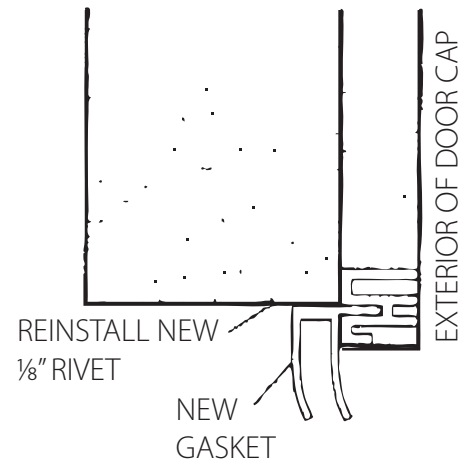

OLD GASKET REMOVAL

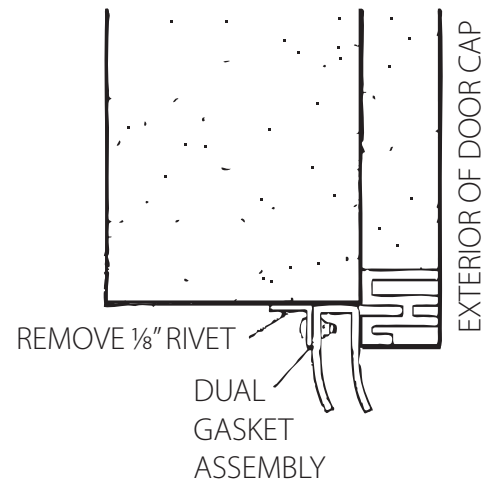

Instructions:

1. Disconnect the power supply to the vapor-proof light junction box on the interior of the door panel.
2. Disconnect the crossover cord from the vapor-proof light junction box. Allow the cord to hang free from the door cap.
3. Unscrew hinge screws from door panel and carefully remove door cap.
4. Lay door cap on work surface with the door cap interior facing up.
5. Loosen mounting bolts for gasket retainer plate and remove old gasket. Move retainer plate forward to cover cavity and tighten bolts.
6. Inspect and clear plastic extrusion ridge that runs along the inside of door offset.
7. After centering new gasket along bottom of door cap, drive gasket stem into ridge using wood block and hammer with light taps.
8. Reinstall door and connect power.
9. New gasket should slightly drag on step plate or floor surface. Gasket may need to be trimmed if it drags excessively and inhibits door closure.

Alternate Installation:

10. If door cap does not have plastic extrusion along bottom, install new gasket stem under retainer plate. Ensure that gasket firmly sets against the inside of door cap offset.

OLD GASKET REMOVAL

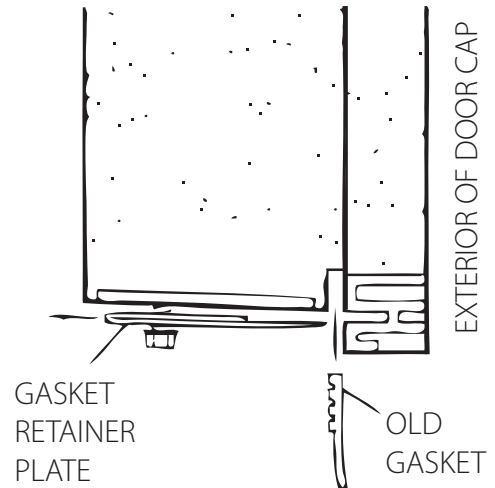

NEW GASKET INSTALLATION

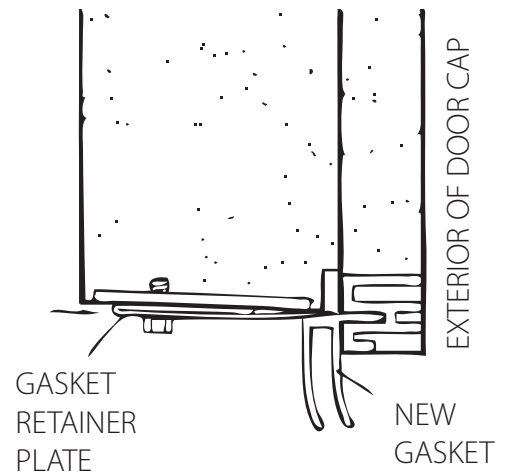

NEW GASKET ALTERNATE INSTALLATION

