



# APPLICATION GUIDELINE

ThermoSaver Hot Gas Defrost systems provide for a fast defrost alternative over comparable electric defrost systems. They can be used on any freezer or cooler application ranging in room temperatures from  $-30^{\circ}\text{F}$  to  $34^{\circ}\text{F}$ , with capacity ranges of 2 – 30HP, available as an Indoor Air Cooled, Outdoor Air Cooled, Remote or Water Cooled Condensing unit.

The basic piping, layout and design concept are covered in pages 3 and 4 of this manual. These should be reviewed first to understand the refrigerant flow and to identify the special defrost components used.

Important design points are:

1. Concept is similar to a “three-pipe” hot gas bypass system yet only uses two pipes (shares the liquid line and reduces field piping and labour cost). The main difference is the third shared pipe does not need to be oversized. During the initial hot gas cycle Liquid is fed first, then a mixture, only at the latter part of the cycle is it all hot gas. (so high pressure drops are not realized)
2. The defrost is very fast - less than 10 minutes and uses pressure controls (not temperature) for termination and fan delay functions. (results in faster response time)
3. The evaporator used must be included together with the Condensing Unit (i.e. sold/supplied as a complete system package) as it must be properly selected and piped with the correct defrosting components. Line runs and sizes need to be reviewed. (keep within 100 feet) Electric heat drain pans (using time –delay relay function) are recommended in place of hot gas loops.
4. This unique defrost system can be used with either one or multiple evaporators (regardless of the application, freezer or cooler) and all can be defrosted at once.
5. There does exist added suction pressure drop across the outlet pressure regulator (CPR) and suction accumulator so for load calculation purposes do not undersize (keep adequate added safety margin).
6. Excessive system refrigerant charges (from long runs, oversized evaps, oversized receivers) must be avoided. During the latter portion of the defrost cycle and post defrost refrigeration cycle, refrigerant will flood back to the suction accumulator. Keeping the overall system charge low will reduce the amount of floodback.

To ensure maximum design benefits:

1. Review the line runs and sizes (use short and properly sized liquid lines -do not oversize).
2. Use minimal refrigerant charge. Use only enough to satisfy the condenser flooding valve (low ambient control), receiver seal, liquid line and evaporator charge requirements.
3. Field adjust these five critical defrost components to proper initial settings:
  - (a) Outlet Press Regulator (CPR) Valve- Must be set to the lowest possible setting (approx  $10-15^{\circ}\text{F}$  above evap temp design) without compromising post defrost pull-down time. This valve is not primarily set for motor compressor motor overload protection, it's main purpose is to keep a pressure differential during the defrost .
  - (b) Defrost Termination Control- Must not be set too high. Keep to lowest possible setting (as soon as ice and frost has melted and pressure then starts to rise). Higher settings result in longer defrosts (over 10 minutes) and excessive floodback.
  - (c) Fan Delay Control- Must not be set too low (as will promote flooding of the evap resulting in increased amount of refrigerant flood back after the defrost)
  - (d) Timeclock - Fail safe Time should not be set greater than 20 minutes. If the defrost is taking too long then an issue exists with the control settings or application. (This must be identified and resolved.)
  - (e) Time –Delay (Hot gas cycle) – Must be set at least for two minutes (up to 5 min) in order to (i) pump out all remaining refrigerant in the evaporator and (ii) Pre-heat the drain pan prior to the hot gas entering the coil. This timer setting must be longer than the compressor anti-short cycle setting (if equipped)

Important initial set points are covered on pages 8 and 9 in this manual and must be followed. Further adjustments can then be made to suit local field conditions.

# THERMOSEVER OPERATION

The ThermoSaver defrost cycle system provides a quicker defrost period (up to three times faster) over the conventional electric defrost system. This minimizes the rise in box temperature during the defrost which reduces product deterioration and increases the system efficiency. This results in lower running times and reduced energy costs. When using more than one evaporator on the same condensing unit, all the evaporators can be defrosted simultaneously.

All ThermoSaver components are completely factory installed, pre-piped and pre-wired. An extra third pipe (hot gas line) is not required.

This significantly reduces the overall installation time and cost. Factory installed standard components include the evaporator distributor nozzle, thermostatic expansion valve (TXV), liquid line solenoid valve, hot gas solenoid valve, liquid check valves, three way solenoid valve, defrost regulating valve, suction accumulator, defrost termination / fan delay pressure controls and drain pan heater and timeclock. Room thermostat and suction filter are optional to be field installed.

The following diagrams explain the ThermoSaver operation during both refrigeration and defrost cycles.

## REFRIGERATION

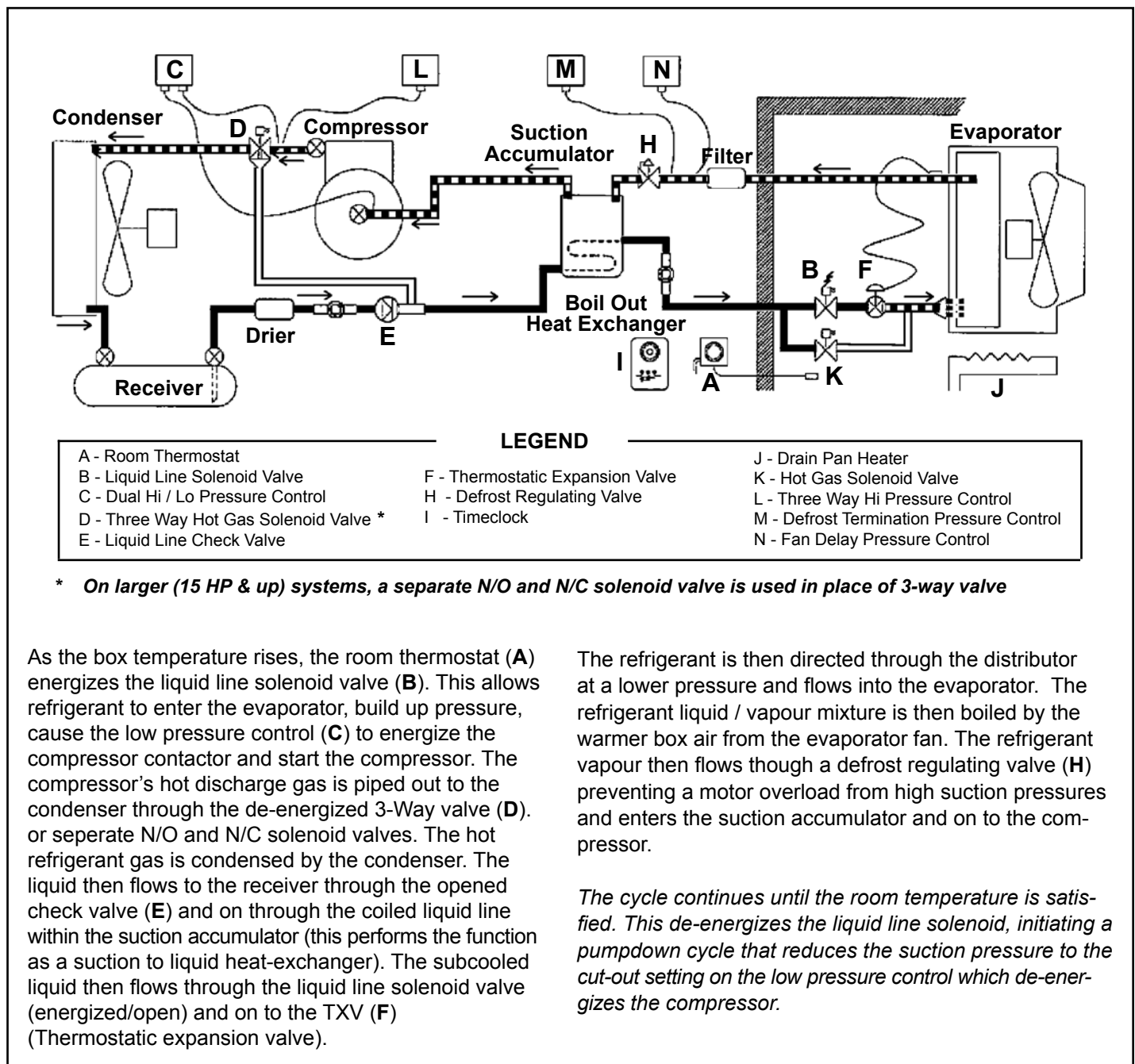

# THERMOSEVER OPERATION

## DEFROST

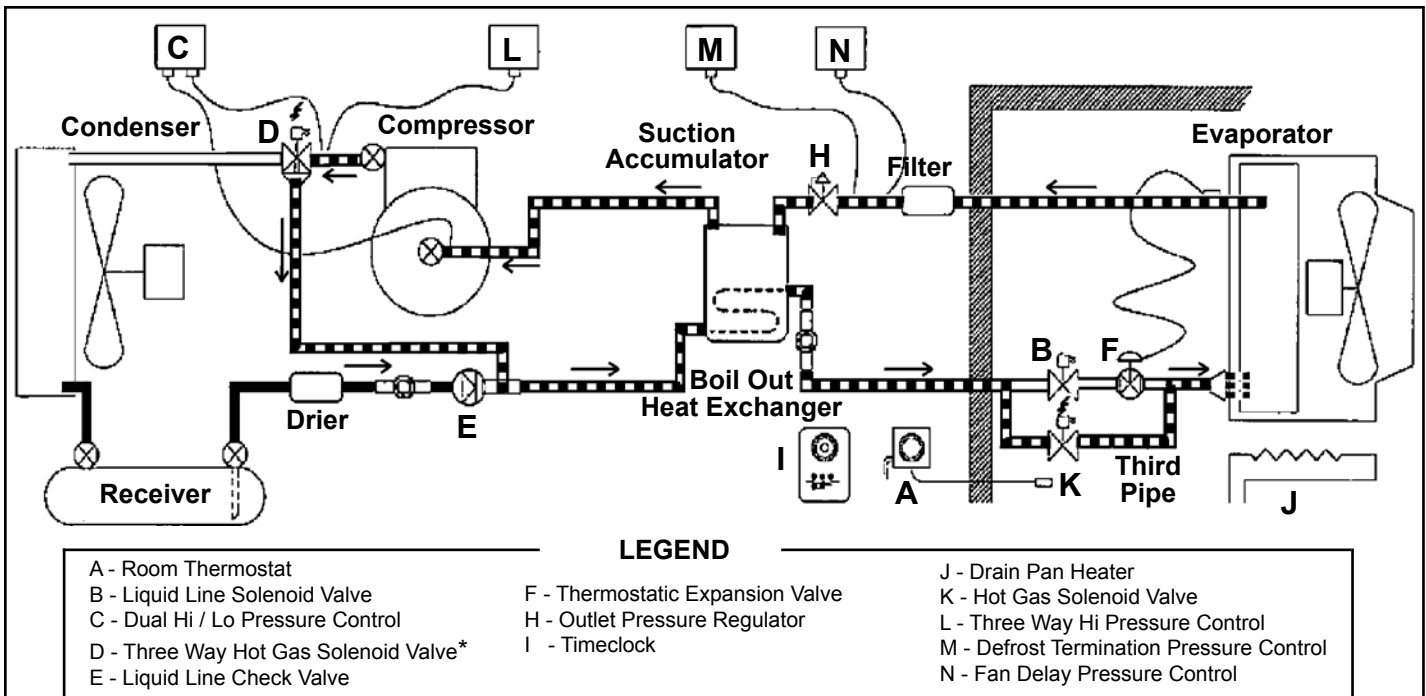

\* On larger (15 HP & up) systems, a separate N/O and N/C solenoid valve is used in place of 3-way valve

The refrigeration cycle results in frost formation on the surface of the evaporator. This frost will eventually build up to the point where it will restrict the air flow causing a loss of refrigeration capacity. To prevent this, a timeclock (I), usually set to repeat every 6 or 8 hours, initiates a defrost cycle which melts the frost.

The clock de-energizes (closes) the liquid line solenoid valve which causes the compressor to pumpdown and shut off from the low pressure control. The clock also energizes the drain pan heater (J) in the evaporator and timer relay which after a two or more minute delay energizes (opens) the 3-way valve and hot gas solenoid valve (K) which then builds up pressure in the evaporator causing the low pressure control to close and start the compressor.

The hot discharge gas from the compressor flows through the 3-way valve forcing all the liquid left in the liquid line into the evaporator. If pressure builds up too high the 3-way valve safety pressure control (L) will de-energize the solenoid valve and allow pressure to relieve through the condenser.

Pressures within the evaporator will increase during the defrost. The outlet pressure regulator (H) maintains a desired pressure differential in the system, as well as reducing the amount of liquid refrigerant back to the accumulator. The regulator also minimizes any high suction pressure avoiding compressor motor overloads.

Once all the frost has melted the pressure will continue to rise until the defrost termination pressure control (M) energizes the timeclock's internal solenoid terminating the defrost cycle. The 3-way valve, hot gas valve solenoids are then de-energized. The liquid line solenoid valve opens and the compressor continues to run. The evaporator fans do not start up until the pressure in the evaporator is low enough to close the Fan delay control (N). By delaying the fans this allows any moisture left on the coil to drain away or freeze. As soon as the evaporator fans are energized the system will then resume back to the refrigeration cycle.

*The cycle continues until the room temperature is satisfied.*

*This de-energizes the liquid line solenoid, initiating a pumpdown cycle that reduces the suction pressure to the cut-out setting on the low pressure control which de-energizes the compressor.*

# WIRING DIAGRAMS

## TYPICAL SYSTEM WITH LOW PROFILE EVAPORATOR

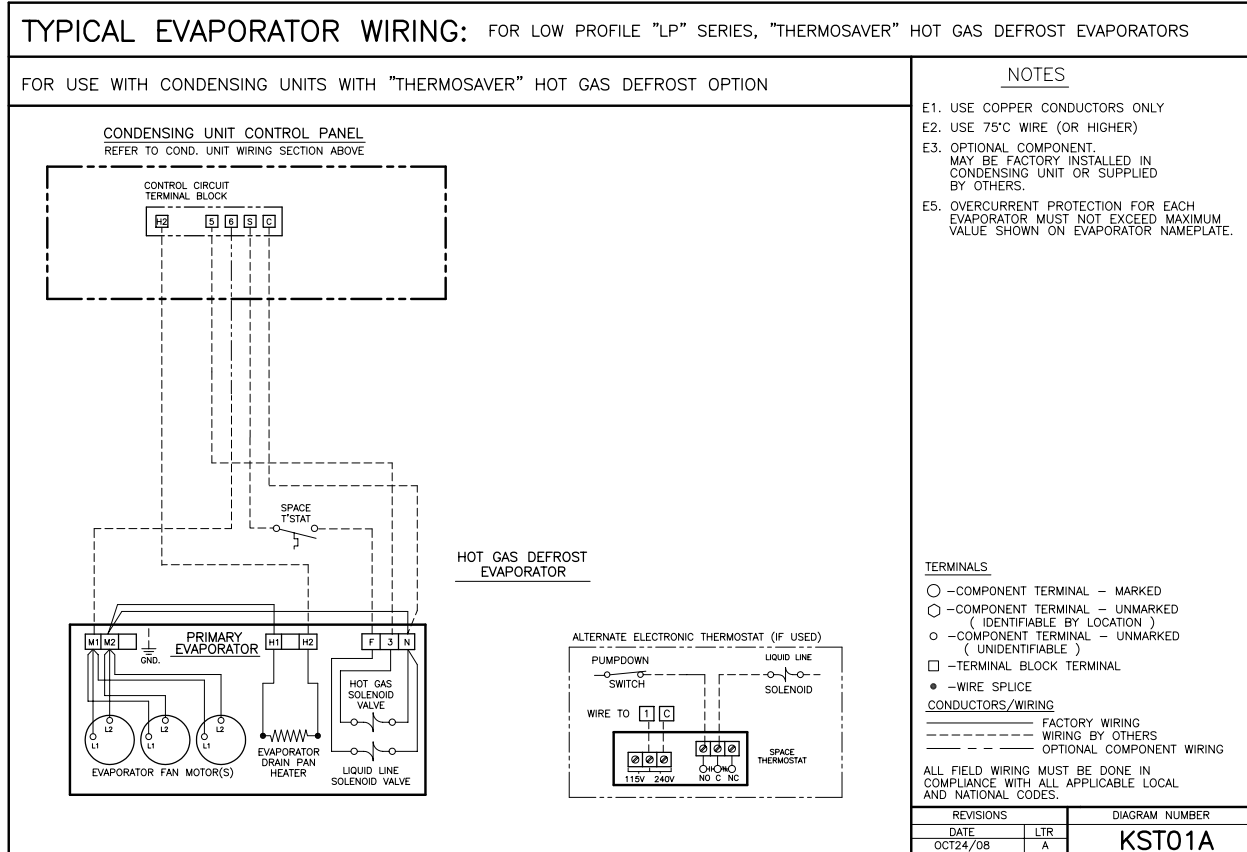
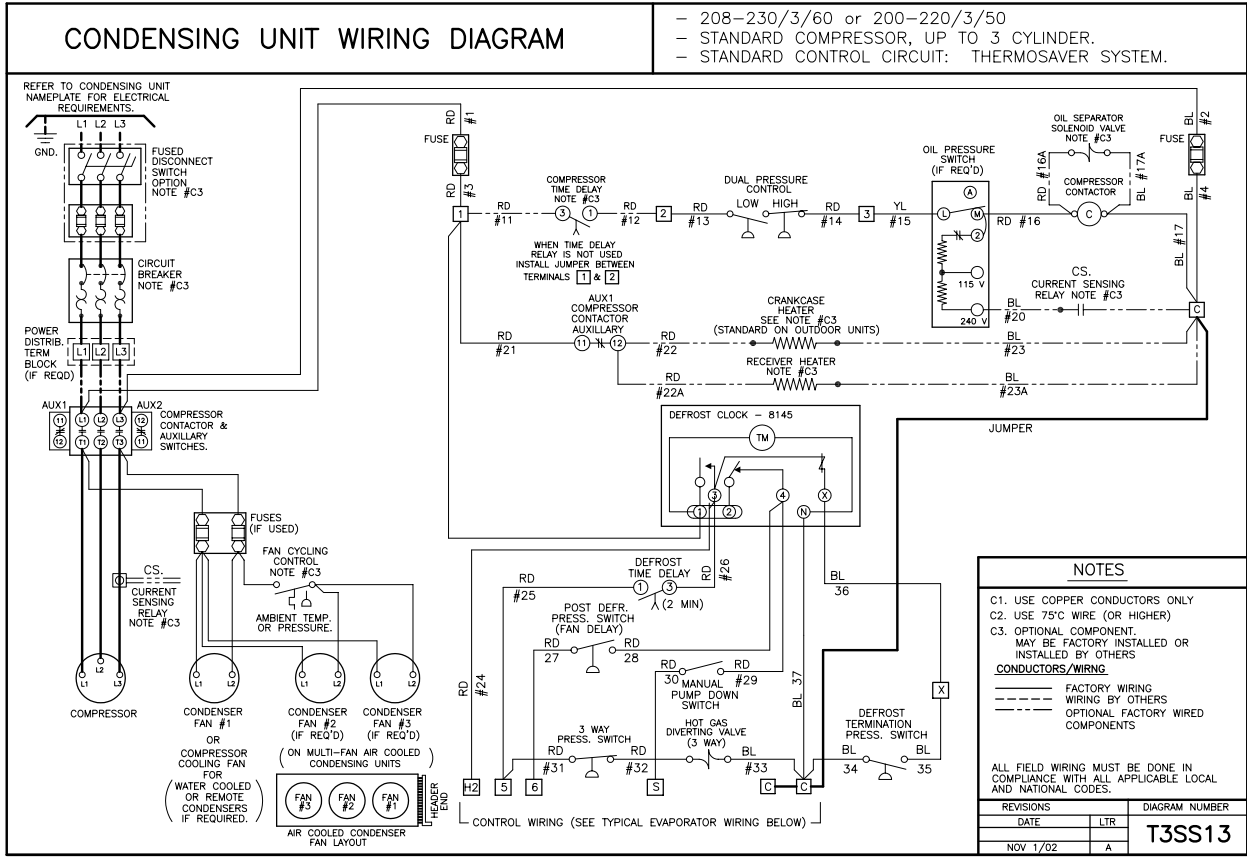



# WIRING DIAGRAMS

## TYPICAL SYSTEM WITH HIGH PROFILE EVAPORATOR

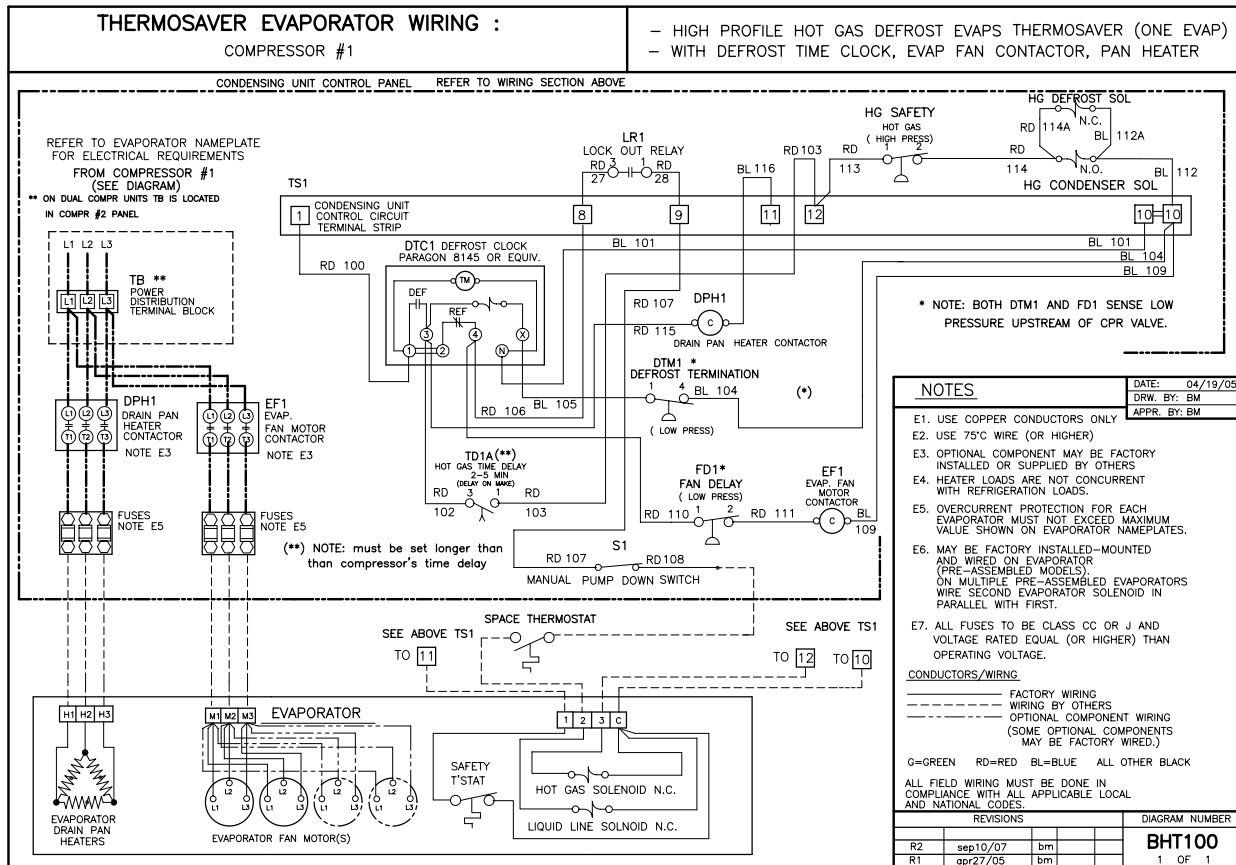
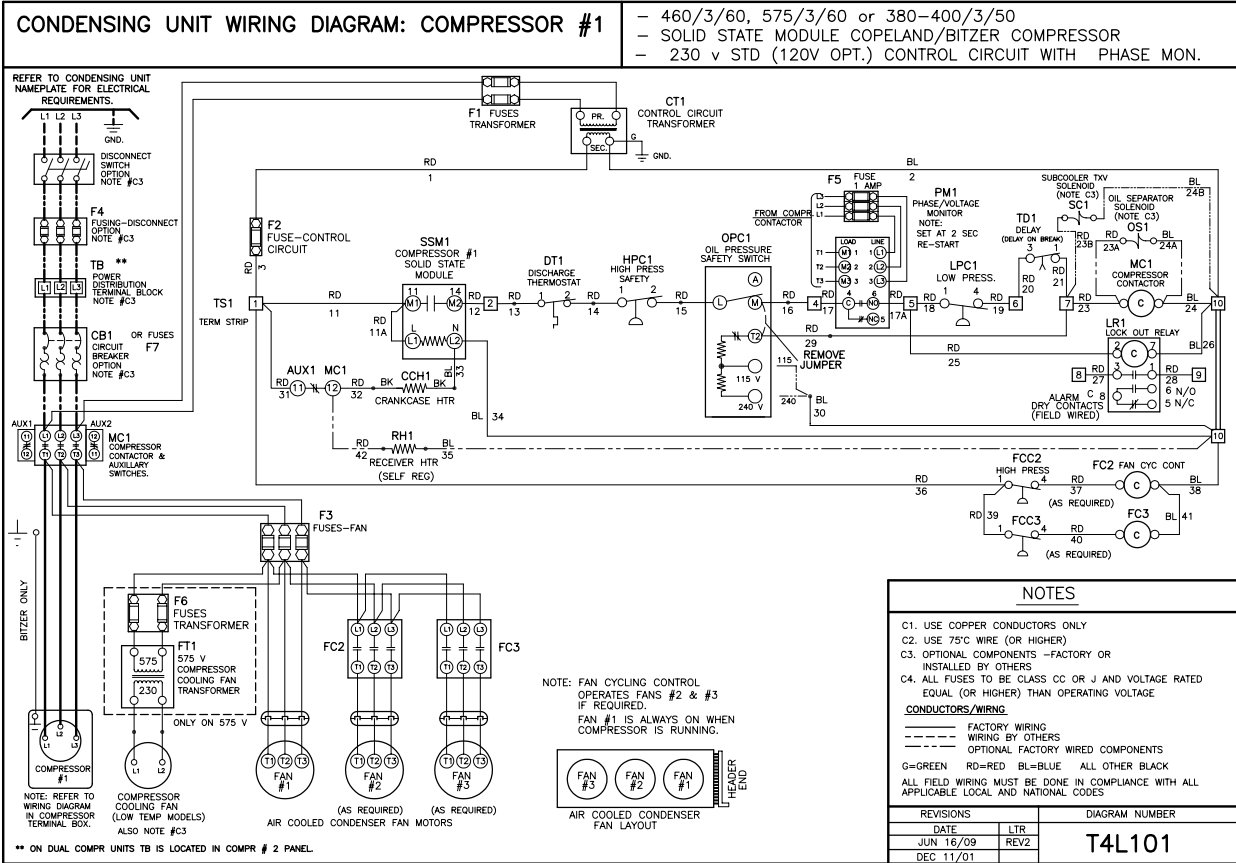

# INSTALLATION

For general installation procedures refer to the Condensing unit Installation and Maintenance instructions included with the unit. (Bulletin K40-CU-IM, part # 1068155)

## THERMOSEVER CONTROL SETTINGS

The following controls should be initially set as listed below and then **MUST** be re-adjusted to suit local field conditions.

### Dual (HI-Lo) Pressure Control

The High side setting is strictly a safety cut out (in the event of a high pressure build up due to condenser fan failure, blocked condenser air or restriction in the discharge line etc.) The control is normally closed. The low side setting should be adjusted for a pumpdown mode. When the space thermostat is satisfied the liquid line solenoid de-energizes (closes) causing the pumpout. The low pressure control then opens up, de-energizing the compressor contactor coil.

*See Table 1 for initial settings*

### Three-way High Pressure Control

During the defrost cycle the three way solenoid valve (or separate N/O and N/C hot gas solenoid valve) is energized by the three way pressure switch which is normally closed. This control only operates during the defrost cycle. It is a safety control to prevent the discharge pressure from reaching excessive pressures. It is important this is set high enough to prevent unnecessary short cycling. In the event of a trip it will de-energize the Three way solenoid valve. This control **MUST** be set to cut out at a lower cut-out setting than that of the main high pressure control.

*See Table 1 for initial settings.*

### Defrost Termination Pressure Control

After all the ice and frost has melted on the evaporator coil, the suction pressure will rapidly rise and once a pre-set pressure is reached (the cut-in pressure setting) the control closes and energizes the Timeclock's "X" terminal which then terminates the hot gas defrost.

This control must be carefully set to suit the local field conditions. Too low of a cut in setting will terminate the defrost too soon (which may still leave some ice/frost on the evaporator). Too high of a cut-in setting may extend the defrost period and cause excessive floodback to the compressor as well as adding unnecessary heat to the evaporator. *See Table 1 for initial settings.*

An ideal setting for the control is after the evaporator coil is completely clear of frost, there is an approx 2 minute time period before the defrost cycle terminates.

### Fan Delay Pressure Control

Once the defrost cycle has terminated the refrigeration cycle then starts back up (liquid line solenoid opens and feeds the TXV). To prevent any moisture and water droplets from blowing off the evaporator coil the fans must be delayed. The fan delay pressure control is open (above the cut-in set point) at the start of the cycle, which de-energizes the fan contactor. Once the suction pressure starts to drop, the evaporator becomes colder and re-freezes any water left remaining on the coil. At this time the pressure drops to the cut-in set point and energizes the fan contactor. The fan delay pressure control should not be set at too low of a cut-in setting since it will delay the fans too long. *See Table 1 for initial settings.*

### Outlet Pressure Regulator

During refrigeration mode, this valve regulates the outlet pressure and ensures that the suction pressure does not rise above the set point (adjustable). This limits the pressure to the compressor to an acceptable pressure that prevents the compressor motor from overloading. During defrost this regulator provides ideal pressure differential through the evaporator during defrost. Further, the properly set regulator can minimize the flood back. A correct setting of the regulator plays a crucial role in defrost operation. The maximum setting should be no higher than the pressure equivalent to the compressor maximum allowed saturated suction temperature (SST). The minimum setting should be no lower than the pressure equivalent of 15°F above the compressor normal operating evaporating temperature. *See Table 2 for initial settings.*

# INITIAL PRESSURE SETTINGS (PSIG)

## SETTINGS MUST BE FINE TUNED TO SUIT FIELD CONDITIONS

Note: Various control manufacturer types result in different range scale and differential configurations. (Refer to the control manufacturers instructions for these details) The table below covers the switch action as High or Low event and the applicable switch position (open or closed). Most manufacturers use the Range scale as the high event value. The differential setting value will be the difference between the high event less the low event pressure.

TABLE 1	R22		R404A	
	HIGH EVENT	LOW EVENT	HIGH EVENT	LOW EVENT
PRESSURE CONTROL				
Main Low Press	Set for Pumpdown mode and suited to Application and Ambient - see P.27 of Installation Manual			
Main High Press (Air Cooled)	360 (open)	300 (close)	400 (open)	340 (close)
Main High Press (Water Cooled)	300 (open)	240 (close)	360 (open)	300 (close)
Three-way High Press (Air Cooled) *	340 (open)	280 (close)	380 (open)	320 (close)
Three-way High Press (Water Cooled) *	280 (open)	220 (close)	340 (open)	280 (close)
Defrost Termination Press	120 (close)	80 (open)	145 (close)	90 (open)
Fan Delay Press (Med Temp application)	70 (open)	40 (close)	85 (open)	50 (close)
Fan Delay Press (Low Temp application)	55 (open)	25 (close)	70 (open)	35 (close)

\* Must be set at 20 PSIG lower than the main safety HP control.

### Defrost Timeclock

This controls the refrigeration and defrost cycles. During refrigeration it provides power to the space thermostat and liquid line solenoid valve. During the defrost cycle it de-energizes the power to the space thermostat and liquid line solenoid valve and energizes the drain pan heater and hot gas time delay relay (2 minutes or more). After the delay it then energizes the hot gas solenoid valve and three way hot gas valve. The clock has an internal solenoid relay that once energized by the defrost termination pressure control, switches the clock contacts back to the refrigeration cycle mode. The clock has a fail safe setting that will terminate the defrost after a set time period.

*Suggested initial settings: 4 defrosts per day / 20 minutes fail safe MAX.*

### Hot Gas Time Delay Relay

This timer allows the drain pan to be pre-heated prior to the defrost cycle. This timer also allows the evaporator

to be pumped out prior to the defrost cycle. In some applications (extra- low temp. freezers) the timer may have to be set for a longer delay if the drain pan does not clear properly, and must be set at a longer delay than the compressor time delay (if equipped).

*Suggested initial setting: 2 minutes.*

### Note:

1. Liquid line only needs to be sized based on refrigeration mode. Long line run (over 100 ft) and oversizing will result in excessive flood back during defrost cycle.
2. During the start of the defrost cycle (timeclock switches to defrost) **ensure the time delay is adjusted to** (1) properly pre-warm the drain pan heater and (2) ensure all of the refrigerant is removed from the low side system and has performed a pumpdown cycle. Increase the setting if necessary for a longer delay.

## INITIAL HOT GAS REGULATING VALVE SETTING SETTINGS MUST BE FINE TUNED TO SUIT FIELD CONDITIONS

TABLE 2

EVAP TEMP. (°F)	R22 (PSIG)	R404A (PSIG)
-40 to -30	15	20
-29 to -20	20	30
-19 to 0	40	50
1 to 10	50	65
11 to 25	60	80

Note: To speed up pull down during start-up, the regulating valve may be opened temporarily.

# TROUBLESHOOTING GUIDE

PROBLEM	POSSIBLE CAUSES
<p><b>Compressor is flooding back</b></p>	<p>It is normal for refrigerant to flood back to the suction accumulator during the latter part of the defrost cycle and after defrost. However if excessive refrigerant floods back past the accumulator then following areas need attention:</p> <ol style="list-style-type: none"> <li>1. Is there an excessive overcharged system charge? Reduce charge.</li> <li>2. Are the defrost controls set up properly? See P. 9 Table 1</li> <li>3. Are liquid lines too big and long? Do not size the liquid by hot gas sizing method. Liquid line should be sized for refrigeration liquid requirement only.</li> <li>4. Defrost cycle is on too long.</li> </ol>
<p><b>Defrost cycle is longer than 15 minutes.</b></p>	<ol style="list-style-type: none"> <li>1. Has drain pan had adequate pre-heat time? (Increase time delay)</li> <li>2. Check that CPR is not set too high. (follow guidelines)</li> <li>3. Check Defrost termination setting. (lower the setting)</li> </ol>
<p><b>Evaporator coil not clear of ice after defrost.</b></p>	<ol style="list-style-type: none"> <li>1. Defrost time too short. Improper defrost (increase termination setting, re-adjust CPR valve, follow guidelines)</li> <li>2. Timeclock defrost time duration setting too short.</li> <li>3. Inadequate hot gas supply. Malfunction of Three-way or HG solenoid valves.</li> <li>4. Not enough defrosts per day.</li> <li>5. Excessive infiltration. Reduce humidity, install air curtains</li> </ol>
<p><b>Ice building up at drain pan.</b></p>	<ol style="list-style-type: none"> <li>1. Pre-heat cycle too short (increase time delay)</li> <li>2. Improper slope in drain pan.</li> <li>3. Blocked drain line (unheated, not insulated)</li> <li>4. Drain pan heater issue - low voltage, miswiring.</li> <li>5. Not enough defrosts per day</li> <li>6. Lack of or improper P-trap in drain line.</li> </ol>
<p><b>Compressor does not run during defrost cycle.</b></p>	<ol style="list-style-type: none"> <li>1. It is normal for the compressor not to run during the drain pan pre-heat period. (unless due to compressor pump-down)</li> <li>2. Compressor anti-short cycle time delay is still timing out after drain pan heater timer has timed out. Ensure compressor timer is not set for longer time period than the Drain Pan Timer. (i.e. if compressor is set at 2 minutes, then pan timer should no shorter than 3 minutes. If compressor timer is set at 5 minutes then pan timer must be at least at 6 minutes, etc.) Note: Energizing the hot gas solenoids without the compressor starting up can result in major defrosting problems.</li> </ol>

# SERVICE PARTS LIST

DESCRIPTION	PART NUMBER
Hot Gas Time Delay Relay	1049535
Defrost Termination Pressure Control	1049770 (1/4 SAE)
Fan Delay Pressure Control	1045264 (1/4 SAE)
Three Way Valve Pressure Control	1064271 (1/4 SAE)

# PROJECT INFORMATION

System	
Model Number	Date of Start-Up
Serial Number	Service Contractor
Refrigerant	Phone
Electrical Supply	Fax

## Finished Goods Warranty

The terms and conditions as described below in the General Warranty Policy cover all products manufactured by National Refrigeration.

### GENERAL WARRANTY POLICY

Subject to the terms and conditions hereof, the Company warrants all Products, including Service Parts, manufactured by the Company to be free of defects in material or workmanship, under normal use and application for a period of one (1) year from the original date of installation, or eighteen (18) months from the date of shipment from the Company, whichever occurs first. Any replacement part(s) so supplied will be warranted for the balance of the product's original warranty. The part(s) to be replaced must be made available in exchange for the replacement part(s) and reasonable proof of the original installation date of the product must be presented in order to establish the effective date of the warranty, failing which, the effective date will be based upon the date of manufacture plus thirty (30) days. Any labour, material, refrigerant, transportation, freight or other charges incurred in connection with the performance of this warranty will be the responsibility of the owner at the current rates and prices then in effect. This warranty may be transferred to a subsequent owner of the product.

### THIS WARRANTY DOES NOT COVER

(a) Damages caused by accident, abuse, negligence, misuse, riot, fire, flood, or Acts of God (b) damages caused by operating the product in a corrosive atmosphere (c) damages caused by any unauthorized alteration or repair of the system affecting the product's reliability or performance (d) damages caused by improper matching or application of the product or the product's components (e) damages caused by failing to provide routine and proper maintenance or service to the product (f) expenses incurred for the erecting, disconnecting, or dismantling the product (g) parts used in connection with normal maintenance, such as filters or belts (h) products no longer at the site of the original installation (i) products installed or operated other than in accordance with the printed instructions, with the local installation or building codes and with good trade practices (j) products lost or stolen.

**No one is authorized to change this WARRANTY** or to create for or on behalf of the Company any other obligation or liability in connection with the Product(s). There is no other representation, warranty or condition in any respect, expressed or implied, made by or binding upon the Company other than the above or as provided by provincial or state law and which cannot be limited or excluded by such law, nor will we be liable in any way for incidental, consequential, or special damages however caused.

The provisions of this additional written warranty are in addition to and not a modification of or subtraction from the statutory warranties and other rights and remedies provided by Federal, Provincial or State laws.



**General Sales, Parts & Service Manufacturing & Engineering**  
135 Little Nine Drive, Morehead City, NC 28557  
252-240-2829 • 1-800-24-BALLY • FAX: 252-240-0384  
e-mail: [ballysales@ballyrefboxes.com](mailto:ballysales@ballyrefboxes.com) • [www.ballyrefboxes.com](http://www.ballyrefboxes.com)



DISTRIBUTED BY: